

Decidable Problems for Probabilistic Automata on Infinite Words

Krishnendu Chatterjee and Mathieu Tracol

IST Austria (Institute of Science and Technology Austria)

Am Campus 1

A-3400 Klosterneuburg

Technical Report No. IST-2011-0004

<http://pub.ist.ac.at/Pubs/TechRpts/2011/IST-2011-0004.pdf>

April 11, 2011

Copyright © 2011, by the author(s).

All rights reserved.

Permission to make digital or hard copies of all or part of this work for personal or classroom use is granted without fee provided that copies are not made or distributed for profit or commercial advantage and that copies bear this notice and the full citation on the first page. To copy otherwise, to republish, to post on servers or to redistribute to lists, requires prior specific permission.

Decidable Problems for Probabilistic Automata on Infinite Words

Krishnendu Chatterjee (IST Austria)

Mathieu Tracol (IST Austria)

Abstract

We consider probabilistic automata on infinite words with acceptance defined by parity conditions. We consider three qualitative decision problems: (i) the positive decision problem asks whether there is a word that is accepted with positive probability; (ii) the almost decision problem asks whether there is a word that is accepted with probability 1; and (iii) the limit decision problem asks whether for every $\epsilon > 0$ there is a word that is accepted with probability at least $1 - \epsilon$. We unify and generalize several decidability results for probabilistic automata over infinite words, and identify a robust (closed under union and intersection) subclass of probabilistic automata for which all the qualitative decision problems are decidable for parity conditions. We also show that if the input words are restricted to lasso shape words, then the positive and almost problems are decidable for all probabilistic automata with parity conditions.

1 Introduction

Probabilistic automata and decision problems. Probabilistic automata for finite words were introduced in the seminal work of Rabin [15] as an extension of classical finite automata. Probabilistic automata on finite words have been extensively studied (see the book [14] on probabilistic automata and the survey of [5]). Probabilistic automata on infinite words have been studied recently in the context of verification [2, 1]. We consider probabilistic automata on infinite words with acceptance defined by safety, reachability, Büchi, coBüchi, and parity conditions.

Qualitative decision problems. We consider three *qualitative* decision problems for probabilistic automata on infinite words [1, 10]: given a probabilistic automaton with an acceptance condition, (i) the *positive* decision problem asks whether there is a word that is accepted with positive probability (probability > 0); (ii) the *almost* decision problem asks whether there is a word that is accepted almost-surely (with probability 1); and (iii) the *limit* decision problem asks whether for every $\epsilon > 0$ there is a word that is accepted with probability at least $1 - \epsilon$. The qualitative decision problems for probabilistic automata are the generalization of the emptiness and universality problem for deterministic automata.

Undecidability results. The decision problems for probabilistic automata on finite words have been extensively studied [14, 5], and the main results establish the undecidability of the quantitative version of the decision problems (where the thresholds are a rational $0 < \lambda < 1$, rather than 0 and 1). The undecidability results for the qualitative decision problems for probabilistic automata on infinite words are quite recent. The results of [1] show that the positive (resp. almost) decision problem is undecidable for probabilistic automata with Büchi (resp. coBüchi) acceptance condition, and as a corollary both the positive and almost decision problems are undecidable for parity acceptance conditions. The results of [1] also show that the positive (resp. almost) decision problem is decidable for probabilistic automata with coBüchi (resp. Büchi) acceptance condition, and these results have been extended to the more general case of stochastic games with imperfect information in [3] and [11].

The positive and almost problem are decidable for safety and reachability conditions, and also for probabilistic automata over finite words. It was shown in [10] that the limit decision problem is undecidable even for probabilistic finite automata, and the proof can be easily adapted to show that the limit decision problem is undecidable for reachability, Büchi, coBüchi and parity conditions (see [7] for details).

Decidable subclasses. The root cause of the undecidability results is that for arbitrary probabilistic automata and arbitrary input words the resulting probabilistic process is complicated. As a consequence several researchers have focussed on identifying subclasses of probabilistic automata where the qualitative decision problems are decidable. The work of [6] presents a subclass of probabilistic automata, namely hierarchical probabilistic automata (HPA), and show that the positive and almost problems are decidable for Büchi and coBüchi conditions. The work of [10] presents a subclass of probabilistic automata, namely #-acyclic automata, and show that the limit reachability problem is decidable for this class of automata over finite words. The two subclasses HPA and #-acyclic automata are incomparable in expressive power.

Our contributions. In this work we unify and generalize several decidability results for probabilistic automata over infinite words, and identify a robust subclass of probabilistic automata for which all the qualitative decision problems are decidable for parity acceptance conditions. For the first time, we study the problem of restricting the structure of input words, as compared to the probabilistic automata, and show that if the input words are restricted to *lasso shape* words, then the positive and almost problems are decidable for all probabilistic automata with parity acceptance conditions. The details of our contributions are as follows.

1. We first present a very general result that would be the basic foundation of the decidability results. We introduce a notion of *simple* probabilistic process: the non-homogeneous Markov chain induced on the state space of a probabilistic automaton by an infinite word is simple if the tail σ -field of the process has a particular structure. The structure of the tail σ -field is derived from Blackwell-Freedman-Cohn-Sonin *decomposition-separation theorem* [4, 8, 16] on finite non-homogeneous Markov chains which generalizes

the classical results on homogeneous Markov chains.

2. We then show that if we restrict the input words of a probabilistic automaton to those which induce simple processes, then the positive and almost decision problems are decidable for parity conditions. We establish that these problems are PSPACE-complete.
3. We then introduce the class of *simple probabilistic automata* (for short simple automata): a probabilistic automaton is simple if every input infinite words induces simple processes on its state space. This semantic definition of simple automata uses the decomposition-separation theorem. We present a *structural (or syntactic)* characterization of the class of simple automata, which relies on the structure of the *support graph* of the automata. From our structural characterization it follows that given a probabilistic automaton, it is a PSPACE-complete problem whether the automaton is simple. We show that the model of simple automata generalizes both the models of HPA and #-acyclic automata. We show that for simple automata the positive, almost and limit problems are decidable for parity conditions, and are PSPACE-complete. Thus our results both unify and generalize two different results for decidability of subclasses of probabilistic automata. Moreover, we show that simple automata are *robust*, i.e., closed under union and intersection. Thus we are able to identify a robust subclass of probabilistic automata for which all the qualitative decision problems are decidable for parity conditions.
4. Finally, we study for the first time the effect of restricting the structure of input words for probabilistic automata, rather than restricting the structure of probabilistic automata. We show that for all ultimately periodic (or lasso shape) words and for all probabilistic automaton, the probabilistic process induced is a simple one. Hence as a corollary of our first result, we obtain that if we restrict to lasso shape words, then the positive and almost decision problems are decidable (PSPACE-complete) for all probabilistic automata with parity conditions. However, the limit decision problem for the reachability condition is still undecidable for lasso shape words, as well as the Büchi and coBüchi conditions.

In this paper we use deep results from probability theory to establish general results about the decidability of problems on probabilistic automata. We present surprising structural characterizations of semantic notions coming from probability theory in the context of probabilistic automata. The proofs are given in appendix.

2 Preliminaries

Distributions. Given a finite set Q , we denote by $\Delta(Q)$ the set of probability distributions on Q . Given $\alpha \in \Delta(Q)$, we denote by $\text{Supp}(\alpha)$ the support of α , i.e. $\text{Supp}(\alpha) = \{q \in Q \mid \alpha(q) > 0\}$.

Words and prefixes. Let Σ be a finite *alphabet* of letters. A *word* w is a finite or infinite sequence of letters from Σ , i.e., $w \in \Sigma^\omega$. Given a word $w = a_1, a_2, \dots \in \Sigma^\omega$ and $i \in \mathbb{N}$, we define $w(i) = a_i$, and we denote by $w[1..i] = a_1, \dots, a_i$ the prefix of length i of w . Given $j \geq i$, we denote by $w[i..j] = a_i, \dots, a_j$ the subword of w from index i to j . An infinite word $w \in \Sigma^\omega$ is a *lasso shape word* if there exist two finite words ρ_1 and ρ_2 in Σ^* such that $w = \rho_1 \cdot \rho_2^\omega$.

Definition 1 (Finite Probabilistic Table (see [14])). A Finite Probabilistic Table (FPT) is a tuple $\mathcal{T} = (Q, \Sigma, \{M_a\}_{a \in \Sigma}, \alpha)$ where Q is a finite set of states, Σ is a finite alphabet, α is an initial distribution on Q , and the M_a , for $a \in \Sigma$, are Markov matrices of size $|Q|$, i.e., for all $q, q' \in Q$ we have $M_a(q, q') \geq 0$ and for all $q \in Q$ we have $\sum_{q' \in Q} M_a(q, q') = 1$.

Distribution generated by words. For a letter $a \in \Sigma$, let $\delta(q, a)(q') = M_a(q, q')$ denote the transition probability from q to q' given the input letter a . Given $\beta \in \Delta(Q)$, $q \in Q$ and $\rho \in \Sigma^*$, let $\delta(\beta, \rho)(q)$ be the probability, starting from a state sampled accordingly to β and reading the input word ρ , to go to state q . Formally, given $\rho = a_1, \dots, a_n \in \Sigma^*$, let $M_\rho = M_{a_1} \cdot M_{a_2} \cdot \dots \cdot M_{a_n}$. Then $\delta(\beta, \rho)(q) = \sum_{q' \in Q} \beta(q') \cdot M_\rho(q', q)$. We often write $\delta(\beta, \rho)$ instead of $\text{Supp}(\delta(\beta, \rho))$, for simplicity: $\delta(\beta, \rho)$ is the set of states reachable with positive probability when starting from distribution β and reading ρ . As well, given $H \subseteq Q$, we write $\delta(H, \rho)$ for the the set of states

reachable with positive probability when starting from a state in H sampled uniformly at random, and reading ρ .

Homogeneous and non-homogeneous Markov chains. A Markov chain is a sequence of random variables X_0, X_1, X_2, \dots , taking values in a (finite) set Q , with the Markov property: $\mathbb{P}(X_{n+1} = x | X_1 = x_1, X_2 = x_2, \dots, X_n = x_n) = \mathbb{P}(X_{n+1} = x | X_n = x_n)$. Given $n \in \mathbb{N}$, the matrix M_n of size $|Q|$ such that for all $q, q' \in Q$ we have $M_n(q, q') = \mathbb{P}(X_{n+1} = q' | X_n = q)$ is the *transition matrix at time n* of the chain. The Markov chain is *homogeneous* if M_n does not depend on n . In the general case, we call the chain *non-homogeneous*.

Induced Markov chains. Given a FPT with state space Q , given $G \subseteq Q$ and $\rho = a_0, \dots, a_{m-1} \in \Sigma^*$ such that $\delta(G, \rho) \subseteq G$, we define the Markov chain $\{X_n\}_{n \in \mathbb{N}}$ induced by (G, ρ) as follows: the initial distribution, i.e. the distribution of X_0 , is uniform on G ; given $i \in \mathbb{N}$, X_{i+1} is distributed according to $\delta(X_i, a_{i \bmod m})(-)$. Intuitively, $\{X_n\}_{n \in \mathbb{N}}$ is the Markov chain induced on the FPT when reading the word ρ^ω .

Probability space and σ -field. A word $w \in \Sigma^\omega$ induces a probability space $(\Omega, \mathcal{F}, \mathbb{P}^w)$: $\Omega = Q^\omega$ is the set of runs, \mathcal{F} is the σ -field generated by cones of the type $C_\rho = \{r \in Q^\omega \mid r[1..|\rho|] = \rho\}$ where $\rho \in Q^*$, and \mathbb{P}^w is the associated probability distribution on Ω . See [18] for the standard results on this topic. We write $\{X_n^w\}_{n \in \mathbb{N}}$ for the *non-homogeneous* Markov chain induced on Q by w , and given $n \in \mathbb{N}$ let μ_n^w be the distribution of X_n^w on Q :

$$\text{Given } q \in Q, \mu_n^w(q) = \mathbb{P}^w[\{r \in \Omega \mid r(n) = q\}]$$

The σ -field \mathcal{F} is also the smallest σ -field on Ω with respect to which all the X_n^w , $n \in \mathbb{N}$, are measurable. For all $n \in \mathbb{N}$, let $\mathcal{F}_n = \mathcal{B}(X_n^w, X_{n+1}^w, \dots)$ be the smallest σ -field on Ω with respect to which all the X_i^w , $i \geq n$, are measurable. We define $\mathcal{F}_\infty = \bigcap_{n \in \mathbb{N}} \mathcal{F}_n$, called the *tail σ -field of $\{X_n^w\}$* . Intuitively, an event Γ is in \mathcal{F}_∞ if changing a finite number of states of a run r does not affect the occurrence of the run r in Γ .

Atomic events. Given a probability space $(\Omega, \mathcal{F}, \mathbb{P})$ and $\Gamma \in \mathcal{F}$, we say that Γ is *\mathcal{F} -atomic* if $\mathbb{P}(\Gamma) > 0$, and for all $\Gamma' \in \mathcal{F}$ such that $\Gamma' \subseteq \Gamma$ we have either $\mathbb{P}(\Gamma') = 0$ or $\mathbb{P}(\Gamma') = \mathbb{P}(\Gamma)$. In this paper we will use atomic events in relation to the tail σ -field of Markov chains.

Acceptance conditions. Given a FPT, let $F \subseteq Q$ be a set of accepting (or target) states. Given a run r , we denote by $\text{Inf}(r)$ the set of states that appear infinitely often in r . We consider the following acceptance conditions.

1. *Safety condition.* The safety condition $\text{Safe}(F)$ defines the set of paths that only visit states in F ; i.e., $\text{Safe}(F) = \{(q_0, q_1, \dots) \mid \forall i \geq 0. q_i \in F\}$.
2. *Reachability condition.* The reachability condition $\text{Reach}(F)$ defines the set of paths that visit states in F at least once; i.e., $\text{Reach}(F) = \{(q_0, q_1, \dots) \mid \exists i \geq 0. q_i \in F\}$.
3. *Büchi condition.* The Büchi condition $\text{Büchi}(F)$ defines the set of paths that visit states in F infinitely often; i.e., $\text{Büchi}(F) = \{r \mid \text{Inf}(r) \cap F \neq \emptyset\}$.
4. *coBüchi condition.* The coBüchi condition $\text{coBüchi}(F)$ defines the set of paths that visit states outside F finitely often; i.e., $\text{coBüchi}(F) = \{r \mid \text{Inf}(r) \subseteq F\}$.
5. *Parity condition.* The parity condition consists of a priority function $p : Q \rightarrow \mathbb{N}$ and defines the set of paths such that the minimum priority visited infinitely often is even, i.e., $\text{Parity}(p) = \{r \mid \min(p(\text{Inf}(r))) \text{ is even}\}$.

Probabilistic automata. A *Probabilistic Automaton* (PA) is a tuple $\mathcal{A} = (\mathcal{T}, \Phi)$ where \mathcal{T} is a FPT and Φ is an acceptance condition.

Decision problems. Let \mathcal{A} be a PA, and let $\Phi : \Omega \rightarrow \{0, 1\}$ be an acceptance condition. We consider the following decision problems.

1. *Almost problem:* Whether there exists $w \in \Sigma^\omega$ such that $\mathbb{P}_{\mathcal{A}}^w(\Phi) = 1$?
2. *Positive problem:* Whether there exists $w \in \Sigma^\omega$ such that $\mathbb{P}_{\mathcal{A}}^w(\Phi) > 0$?
3. *Limit problem:* Whether for all $\epsilon > 0$, there exists $w \in \Sigma^\omega$ such that $\mathbb{P}_{\mathcal{A}}^w(\Phi) > 1 - \epsilon$?

Proposition 1 summarizes the known results from [1, 7, 10].

Proposition 1. *Given a PA and an acceptance condition Φ , the following assertions hold:*

1. The almost problem is decidable for $\Phi = \text{safety, reachability, Büchi}$, and undecidable for $\Phi = \text{Co-Büchi and parity}$.
2. The positive problem is decidable for $\Phi = \text{safety, reachability, Co-Büchi}$, and undecidable for $\Phi = \text{Büchi and parity}$.
3. The limit problem is decidable for $\Phi = \text{safety}$, and undecidable for $\Phi = \text{reachability, Büchi, Co-Büchi, and parity}$.

3 Simple Processes

In this section we first recall the decomposition-separation theorem, then use it to decompose the tail σ -field of stochastic processes into atomic events. We then introduce the notion of simple processes, which are stochastic processes where the atomic events obtained using the decomposition-separation theorem are *non-communicating*.

3.1 The Decomposition Separation Theorem and tail σ -fields

The structure of the tail σ -field of a general non-homogeneous Markov chain has been deeply studied by mathematicians. Blackwell and Freedman, in [4], presented a generalization of the classical *decomposition theorem* for homogeneous Markov chains, in the context of non-homogeneous Markov chains with finite state spaces. The work of Blackwell and Freedman has been deepened by Cohn [8] and Sonin [16], who gave a more complete picture. We present the results of [4, 8, 16] in the framework of *jet decompositions* presented in [16].

Jets and partition into jets. A *jet* is a sequence $J = \{J_i\}_{i \in \mathbb{N}}$, where each $J_i \subseteq Q$. A tuple of jets (J^0, J^1, \dots, J^c) is called a *partition of Q^ω into jets* if for every $n \in \mathbb{N}$, we have that $J_n^0, J_n^1, \dots, J_n^c$ is a partition of Q . The *Decomposition-Separation Theorem*, in short *DS-Theorem*, proved by Cohn [8] and Sonin [16] using results of [4], is given in Theorem 1. We first define the notion of *mixing* property of jets.

Mixing property of jets. Given a FPT \mathcal{A} , a jet $J = \{J_i\}_{i \in \mathbb{N}}$ is *mixing* for a word w if: given $X_n^w, n \geq 0$ the process induced on Q by w , given $q, q' \in Q$, and a sequence of states $\{q_i\}_{i \in \mathbb{N}}$ such that for all $i \geq 0$ we have $q_i \in J_i$, given $m \in \mathbb{N}$, if $\lim_n \mathbb{P}^w[X_n^w = q_n \mid X_m^w = q] > 0$ and $\lim_n \mathbb{P}^w[X_n^w = q_n \mid X_m^w = q'] > 0$, then we have:

$$\lim_{n \rightarrow \infty} \frac{\mathbb{P}^w[X_n^w = q_n \mid X_n^w \in J_n^k \wedge X_m^w = q]}{\mathbb{P}^w[X_n^w = q_n \mid X_n^w \in J_n^k \wedge X_m^w = q']} = 1$$

Intuitively, a jet is mixing if the probability distribution of a state of the process, conditioned to the fact that this state belongs to the jet, is ultimately independent of the initial state. This extends the notion of mixing process on homogeneous ergodic Markov chains, on which the distribution of a state of the process after a number of steps is close to the stationary distribution, irrespective of the initial state.

Theorem 1 (The Decomposition-Separation Theorem [4, 8, 16]). *Given a FPT $\mathcal{A} = (Q, \Sigma, \{M_a\}_{a \in \Sigma}, \alpha)$, for all $w \in \Sigma^\omega$ there exists $c \in \{1, 2, \dots, |Q|\}$ and a partition (J^0, J^1, \dots, J^c) of Q^ω into jets such that:*

1. *With probability one, after a finite number of steps, a run $r \in \Omega$ enters into one of the jets J^k , $k \in \{1, 2, \dots, c\}$ and stays there forever.*
2. *For all $k \in \{1, 2, \dots, c\}$ the jet J^k is mixing.*

Theorem 1 holds even if Σ is infinite: it is valid for any non-homogeneous Markov chain on a finite state space. In this paper we will focus on finite alphabets only.

Remark. We note that for all $i \in \{1, 2, \dots, c\}$, either $\mu_n^w(J_n^i) \rightarrow_{n \rightarrow \infty} 0$ or there exists $\lambda_i > 0$ such that for n large enough $\mu_n^w(J_n^i) > \lambda_i$. Indeed, if $\mu_n^w(J_n^i) \not\rightarrow_{n \rightarrow \infty} 0$ but there exists a subsequence of $\{\mu_n^w(J_n^i)\}_{n \in \mathbb{N}}$ which goes to zero, then a non zero probability of runs enter J_n^i and leave it afterward infinitely often, which contradicts the first point of Theorem 1. Thus, we can always assume that there exists $\lambda > 0$ such that for all $i \in \{1, 2, \dots, c\}$, for n

large enough, we have $\mu_n^w(J_n^i) > \lambda$. If this is not the case, we just merge the jets J^i such that $\mu_n^w(J_n^i) \rightarrow_{n \rightarrow \infty} 0$ with J^0 , which does not invalidate the properties of the jet decomposition stated by Theorem 1.

For the following of the section, we fix $w \in \Sigma^\omega$ and a partition J^0, J^1, \dots, J^c of Q^ω as in the DS Theorem. Given $i \in \{1, 2, \dots, c\}$ and $n \in \mathbb{N}$, let:

$$\tau_n^i = \{r \in \Omega \mid r(i) \in J_n^i\}, \text{ and } \tau_\infty^i = \bigcup_{N \in \mathbb{N}} \bigcap_{n \geq N} \tau_n^i$$

We now present a result directly from our formulation of the DS Theorem (the result can also be proved using more general results of [8]).

Proposition 2. *For all $i \in \{1, 2, \dots, c\}$, the following assertions hold: (1) $\tau_\infty^i \in \mathcal{F}_\infty$, i.e., τ_∞^i is a tail σ -field event; (2) τ_∞^i is \mathcal{F}_∞ -atomic; i.e., τ_∞^i is an atomic tail event; and (3) $\mathbb{P}^w(\bigcup_{i=1}^c \tau_\infty^i) = 1$.*

The fact that the τ_∞^i are atomic sets of \mathcal{F}_∞ means that all the runs which belong to the same τ_∞^i will satisfy the same *tail* properties. Intuitively, a tail does not depend on finite prefixes. Several important classes of properties are tail properties, as presented in [9]: in particular any parity condition is a tail property.

3.2 Simple processes

Definition 2. *Let $\{X_n^w\}_{n \in \mathbb{N}}$ be a process induced on Q by a word $w \in \Sigma^\omega$, and let μ_n^w be its probability distribution on Q at time n . We say that $\{\mu_n^w\}_{n \in \mathbb{N}}$ is simple if there exist $\lambda > 0$ and two sequences $\{A_n\}_{n \in \mathbb{N}}$ and $\{B_n\}_{n \in \mathbb{N}}$ of subsets of Q such that:*

- $\forall n \in \mathbb{N}, A_n, B_n$ is a partition of Q
- $\forall n \in \mathbb{N}, \forall q \in A_n, \mu_n^w(q) > \lambda$
- $\mu_n^w(B_n) \rightarrow_{n \rightarrow \infty} 0$

The second point of the following proposition shows that the tail σ -field of a simple process can be decomposed as a set of “non-communicating” jets. Intuitively, a jet is non-communicating if there exists a bound $N \in \mathbb{N}$ such that after time N , if a run belongs to the jet, it will stay in it for ever with probability one. The following proposition is a reformulation of the notion of simple process in the framework of jets decomposition.

Proposition 3. *Let $w \in \Sigma^\omega$, and suppose that the process $\{\mu_n^w\}_{n \in \mathbb{N}}$ induced on Q is simple. Then there exists a decomposition of Q^ω into jets, J^0, J^1, \dots, J^c , and $N \in \mathbb{N}$, which satisfy the following properties:*

1. *For all $n \geq N$, all $i \in \{1, 2, \dots, c\}$ and all $q \in J_n^i$, we have $\mu_n(q) > \lambda$.*
2. *For all $i \in \{1, 2, \dots, c\}$ and all $n_2 > n_1 \geq N$ we have $\delta(J_{n_1}^i, w_{n_1+1}^{n_2}) \subseteq J_{n_2}^i$.*
3. *$\mu_n^w(J_n^0) \rightarrow_{n \rightarrow \infty} 0$.*
4. *Each jet $J^i, i \in \{1, 2, \dots, c\}$ is mixing.*

4 Decidable Problems for Simple Processes

In this section we will present decidable algorithms for the decision problems with the restriction of simple processes. We first define the *simple decision problems* that impose the simple process restriction. Given an acceptance condition Φ , we consider the following problems:

1. *Simple almost (resp. positive) problems:* Does there exist $w \in \Sigma^\omega$ such that $\{\mu_n^w\}_{n \in \mathbb{N}}$ is simple and $\mathbb{P}_A^w(\Phi) = 1$ (resp. $\mathbb{P}_A^w(\Phi) > 0$)?
2. *Simple limit problem:* For all $\epsilon > 0$, is there $w \in \Sigma^\omega$ such that $\{\mu_n^w\}_{n \in \mathbb{N}}$ is simple and $\mathbb{P}_A^w(\Phi) > 1 - \epsilon$?

Proposition 4 shows that the decidability and undecidability results of Proposition 1 concerning the positive, almost, and limit safety and reachability problems still hold when we consider their “simple process” version. Propositions 5 and 6 are more interesting as they show that the almost and positive parity problem becomes decidable when restricted to simple processes. Finally, Proposition 7 shows that the “limit” decision problems remain undecidable even when restricted to simple processes.

Proposition 4. *The simple almost (resp. positive) safety and reachability problems are PSPACE-complete, as well as the simple limit safety problem. The simple limit reachability problem is undecidable.*

Proposition 5. *The simple almost parity problem is PSPACE-complete*

Proposition 6. *The simple positive parity problem is PSPACE-complete.*

A corollary of the proofs of Propositions 5 and 6 is that if the simple almost (resp. positive) parity problem is satisfied by a word, then it is in fact satisfied also by a lasso shape word.

Proposition 7. *The simple limit Büchi and coBüchi problems are undecidable.*

From the propositions of this section we obtain the following theorem. In the theorem below the PSPACE-completeness of the limit safety problem follows as for safety conditions the limit and almost problem coincides.

Theorem 2. *The simple almost and positive problems are PSPACE-complete for parity conditions. The simple limit problem is PSPACE-complete for safety conditions, and the simple limit problem is undecidable for reachability, Büchi, coBüchi and parity conditions.*

5 Simple Automata

In this section we introduce the class of simple automata, which is a subclass of probabilistic automata on which every word induces a simple process. We present a structural characterization of simple automata, show that all the associated decision problems are PSPACE-complete, and then show that the class of simple automata is closed under union and intersection.

5.1 Simple Automata

Definition 3 (Simple Automata). *A probabilistic automaton is simple if for all $w \in \Sigma^w$, the process $\{\mu_n^w\}_{n \in \mathbb{N}}$ induced on its state space by w is simple.*

In [10], given $S \subseteq Q$ and $a \in \Sigma$, the authors define the set $S \cdot a$ as the support of $\delta(S, a)$, and in the case where $S \cdot a = S$, the set $S \cdot a^\#$ as the set of states which are recurrent for the homogeneous Markov chain induced on S by the transition matrix M_a . Next, they define the *support graph* \mathcal{G}_A of the automaton \mathcal{A} as the graph whose nodes are the subsets of Q , and such that, given $S, T \subseteq Q$, the couple (S, T) is an edge in \mathcal{G}_A if there exists $a \in \Sigma$ such that $S \cdot a = T$ or $S \cdot a = S$ and $S \cdot a^\# = T$. They present the class of $\#$ -acyclic automata as the class of probabilistic automata whose support graph is acyclic.

Definition 4 ([10]). *A probabilistic automaton \mathcal{A} is $\#$ -acyclic if \mathcal{G}_A is acyclic.*

We now present a natural generalization of this approach, where we consider edges in the support graph labeled by finite words, instead of letters. More precisely, given $S \subseteq Q$ and $\rho \in \Sigma^*$, let $S \cdot \rho = \text{Supp}(\delta(S, \rho))$. If $S \cdot \rho = S$, we define $S \cdot \rho^\#$ as the set of states which are recurrent for the homogeneous Markov chain induced on Q by ρ (i.e. by the transition matrix $\{\delta(q, \rho)(q')\}_{q, q' \in Q}$), and which are reachable from a state in S on this Markov chain.

In the future, we may use the notation $S \xrightarrow{\rho} T$ to signify that $S \cdot \rho = T$, and $S \xrightarrow{\rho^\#} T$ to signify that $S \cdot \rho^\# = T$. We now define the extended support graph of a probabilistic automaton.

Definition 5 (Extended Support Graph). *Let \mathcal{A} be a probabilistic automaton. The extended support graph \mathcal{H}_A of \mathcal{A} is the directed graph whose vertices are the non-empty subsets of Q , and whose edges are the pairs (S, T) such that there exists $\rho \in \Sigma^*$ such that either $S \cdot \rho = T$, or $S \cdot \rho = S$ and $S \cdot \rho^\# = T$. An edge of the type $A \xrightarrow{\rho^\#} B$ is called a $\#$ -edge. An edge of the type $A \xrightarrow{\rho^\#} B$ where $B \subsetneq A$ is called a $\#$ -reduction.*

Example 1.

Consider the following probabilistic automaton \mathcal{A} , with state space $Q = \{s, t, u\}$.

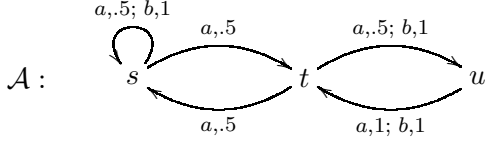

We have $Q \cdot a = Q \cdot a^\# = Q$, and $Q \cdot b = Q \cdot b^\# = Q$. However, $Q \cdot (ab)^\# = \{t, u\}$. Thus, $\{t, u\}$ is reachable from Q in $\mathcal{H}_\mathcal{A}$, but not in $\mathcal{G}_\mathcal{A}$.

In general, given a path in $\mathcal{H}_\mathcal{A}$, we compact the notation of the sequences: instead of $A \xrightarrow{\rho_1} B \xrightarrow{\rho_2} C$, we may write $A \xrightarrow{\rho_1 \cdot \rho_2} C$ since by definition both are sequences in $\mathcal{H}_\mathcal{A}$. Thus, we can associate to any path in $\mathcal{H}_\mathcal{A}$ a sequence: $seq = A_1 \xrightarrow{\rho_1} A_2 \xrightarrow{\rho_2^\#} A_3 \xrightarrow{\rho_3} A_4 \xrightarrow{\rho_4^\#} A_5 \dots \xrightarrow{\rho_k} A_{k+1}$, where the ρ_i are words in Σ^* (possibly empty when i is odd). Given a path seq on $\mathcal{H}_\mathcal{A}$, a *subpath* of seq is a path $seq' = A'_1 \xrightarrow{\rho'_1} A'_2 \xrightarrow{\rho'_2^\#} A'_3 \xrightarrow{\rho'_3} A'_4 \xrightarrow{\rho'_4^\#} A'_5 \dots \xrightarrow{\rho'_{k'}} A'_{k'+1}$ on $\mathcal{H}_\mathcal{A}$ such that $k = k'$, $\rho'_i = \rho_i$ for all $i \in [1; k]$, and such that $A'_1 \subseteq A_1$. A *cycle* is a path such that $A_1 = A_{k+1}$. A cycle is *elementary* if it does not contain any subpath different from itself which is a cycle.

Lemma 1. Any path $seq = A_1 \xrightarrow{\rho_1} A_2 \xrightarrow{\rho_2^\#} \dots \xrightarrow{\rho_k} A_{k+1}$ in $\mathcal{H}_\mathcal{A}$ such that $A_{k+1} \subseteq A_1$ contains an elementary cycle.

In the following of the subsection, we introduce several technical notions useful for the structural characterization of the class of simple automata. Given a probabilistic automaton \mathcal{A} , an *execution tree* is given by an initial distribution $\alpha \in \Delta(Q)$, or a set of states $A \subseteq Q$, and a finite or infinite word ρ . We use the term execution tree informally for the set of execution runs on \mathcal{A} which can be probabilistically generated when the system is initiated in one of the states of $\text{Supp}(\alpha)$ (or A), and when the word ρ is taken as input.

Definition 6 (Leak). A leak is a tuple (A, B, ρ) where $A, B \subseteq Q$ and $\rho \in \Sigma^*$ are such that: $A \neq \emptyset$, $B \neq \emptyset$, $A \cap B = \emptyset$, $(A \cup B) \cdot \rho = A \cup B$, and $(A \cup B) \cdot \rho^\# = B$.

For simplicity, we may use the term leak for a couple (A, ρ) where $A \subseteq Q$ and $\rho \in \Sigma^*$ are such that $A \cdot \rho = A$ and $A \cdot \rho^\# \neq A$.

Definition 7. An execution tree (α, ρ) is said to be chain recurrent for a probabilistic automaton \mathcal{A} if it does not contain a leak. That is, for all $\rho_1, \rho_2 \in \Sigma^*$ such that $\rho_1 \cdot \rho_2$ is a prefix of ρ , $(\delta(\alpha, \rho_1), \rho_2)$ is not a leak. We write $\text{CRec}(\alpha)$ for the set of $\rho \in \Sigma^*$ such that (α, ρ) is a chain recurrent execution tree for \mathcal{A} .

The following key lemma shows that for any probabilistic automaton \mathcal{A} there exists a constant $\gamma(\mathcal{A}) > 0$ such that the probability to reach any state on a chain recurrent execution tree is either 0 or greater than $\gamma(\mathcal{A})$. Given a probabilistic automaton \mathcal{A} , let $\epsilon(\mathcal{A})$ be the smallest non zero probability which appears among the $\delta(q, a)(q')$, where $q, q' \in Q$ and $a \in \Sigma$.

Lemma 2. Let \mathcal{A} be a probabilistic automaton. For all $q \in Q$, all $\rho \in \text{CRec}(q)$ and all $q' \in \text{Supp}(\delta(q, \rho))$ we have $\delta(q, \rho)(q') \geq \epsilon^{2^{2 \cdot |Q|}}$ where $\epsilon = \epsilon(\mathcal{A})$.

5.2 Structural characterization

In this section we prove that the class of simple automata coincides with the following class of structurally simple automata:

Definition 8. A probabilistic automaton \mathcal{A} is structurally simple if the extended support graph of \mathcal{A} does not contain any elementary cycle with a $\#$ -reduction.

Example 2 (Structurally simple Automata).

Consider the following probabilistic automaton:

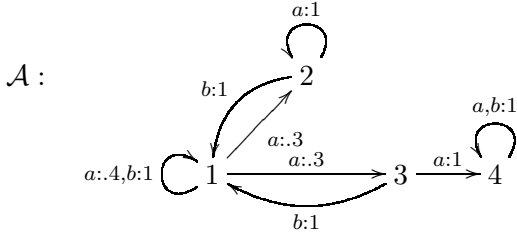

The support graph of \mathcal{A} contains a cycle with a $\#$ -reduction: $(\{1, 2, 3, 4\} \xrightarrow{a^\#} \{2, 4\} \xrightarrow{b \cdot a} \{1, 2, 3, 4\})$. However, \mathcal{A} does not contain any elementary cycle with a $\#$ -reduction, since the only elementary cycles of \mathcal{A} are: $(\{1\}, b)$, $(\{2\}, a)$, $(\{4\}, a)$, $(\{4\}, b)$, and $(\{1, 2, 3\} \xrightarrow{b} \{1\} \xrightarrow{a} \{1, 2, 3\})$. It is straightforward to verify that this automaton is simple.

The five following lemmas are technical and rely on the structure of elementary cycles of extended support graphs. We show that on a structurally simple automaton, given $w \in \Sigma^\omega$, the associated execution tree can be decomposed as a sequence of a bounded number of chain recurrent execution trees. The key Lemma 2 is then used to bound the probabilities which appear.

Lemma 3. *Suppose that \mathcal{A} is structurally simple. Let $A \subseteq Q$ and $\rho \in \Sigma^*$ be such that $A \cdot \rho \subseteq A$. Then there exists $B \subseteq A$ such that (B, ρ) is chain recurrent.*

Lemma 4. *Let $\{\mu_n^w\}_{n \in \mathbb{N}}$ be the process generated by a word $w = a_1, a_2, \dots \in \Sigma^\omega$ on a probabilistic automaton. Given $n \geq 1$ recall that $w[1..n] = a_1, \dots, a_n$. Suppose that there exists $\gamma > 0$ and $N \geq 0$ such that for all $n \geq N$ and all $q \in \text{Supp}(\delta(\alpha, w[1..n]))$ we have $\delta(\alpha, w[1..n])(q) > \gamma$. Then the process is simple.*

We introduce the notion of *Sequence of recurrent execution trees* in order to represent a process which may not be chain recurrent, but which can be decomposed as a sequence of a finite number of chain recurrent execution trees. The *length* of the sequence measures the number of steps which do not belong to a chain recurrent subsequence, and will be useful to bound the "leaks" induced on the sequence. The following Lemma 5 uses the key Lemma 2.

Definition 9 (Sequence of recurrent execution trees). *A sequence of recurrent execution trees is a finite sequence $(\alpha_1, \rho_1), \rho'_1, (\alpha_2, \rho_2), \rho'_2, \dots, (\alpha_k, \rho_k)$ such that:*

- $\rho_k \in \Sigma^\omega$, and for $i \in [1; k-1]$ we have $\rho_i, \rho'_i \in \Sigma^*$
- For all $i \in [2; k]$ we have:
 $\text{Supp}(\alpha_i) \subseteq \text{Supp}(\delta(\alpha_{i-1}, \rho_{i-1} \cdot \rho'_{i-1}))$
- All the execution trees (α_i, ρ_i) are chain recurrent

The length of the sequence is defined as $\sum_{i=1}^{k-1} |\rho'_i|$.

Given an execution tree (α, w) , a subsequence of recurrent execution trees of (α, w) is a sequence of recurrent execution trees $(\alpha_1, \rho_1), \rho'_1, (\alpha_2, \rho_2), \rho'_2, \dots, (\alpha_k, \rho_k)$ such that $\alpha = \alpha_1$ and $w = \rho_1 \cdot \rho'_1 \cdot \rho_2 \cdot \rho'_2 \cdot \dots \cdot \rho_k$.

Lemma 5. *Let \mathcal{A} be a probabilistic automaton. Suppose that there exists $K \in \mathbb{N}$ such that for all execution tree (α, ρ) , there exists a subsequence of recurrent execution trees of length at most K . Then \mathcal{A} is simple.*

Definition 10. *Let $A \subseteq Q$ and $\rho \in \Sigma^*$. Given $B \subseteq Q$, we say that B is $\#$ - ρ -reachable from A , written $A \xrightarrow{\#-\rho} B$, if $B \subseteq \delta(A, \rho)$, and we can decompose ρ in a sequence of subwords $\rho = \rho_1 \cdot \rho_2 \cdot \dots \cdot \rho_{2 \cdot k-1}$ (with ρ_i possibly empty when i is odd), and such that $A \xrightarrow{\rho_1} \xrightarrow{\rho_2^\#} \xrightarrow{\rho_3} \xrightarrow{\rho_4^\#} \dots \xrightarrow{\rho_{2 \cdot k-1}} B$.*

The notion of $\#$ - ρ -reachability satisfies a form of transitivity: given $A, B, C \subseteq Q$ and $\rho = \rho_1 \cdot \rho_2 \in \Sigma^*$, if $A \xrightarrow{\#-\rho_1} B$ and $B \xrightarrow{\#-\rho_2} C$, then $A \xrightarrow{\#-\rho} C$. Lemma 6 is useful to prove Lemma 7, and Proposition 8 follows from Lemma 7 and Lemma 5. Proposition 9 uses Lemma 8 and completes the characterization.

Lemma 6. *Suppose that \mathcal{A} is structurally simple. Let $A, B \subseteq Q$ and $\rho \in \Sigma^*$ be such that $B \subseteq A$ and $A \xrightarrow{\#-\rho} B$. Then there exists $C \subseteq A$ such that (C, ρ) is chain recurrent.*

Lemma 7. *Suppose that \mathcal{A} is structurally simple. Then for all execution tree (α, w) , there exists a subsequence of recurrent execution trees of length at most $2^{|Q|}$.*

Proposition 8. *All structurally simple automata are simple.*

Lemma 8. *Let $seq = A_1 \xrightarrow{\rho_1} A_2 \xrightarrow{\rho_2^\#} A_3 \xrightarrow{\rho_3} A_4 \xrightarrow{\rho_4^\#} \dots \xrightarrow{\rho_{2 \cdot k}^\#} A_1$ be an elementary cycle in \mathcal{H}_A . Then for all $\epsilon > 0$ there exists $K \geq 0, \lambda > 0$ and $i_2, i_4, \dots, i_{2 \cdot k} \geq 1$ such that:*

- *For all $q, q' \in A_1$ and all $k \geq K$ we have $\delta(q, (\rho_1 \cdot \rho_2^{i_2 \cdot k} \cdot \rho_3 \cdot \rho_4^{i_4 \cdot k} \cdot \dots \cdot \rho_{2 \cdot k}^{i_{2 \cdot k} \cdot k})^{2^{|Q|}})(q') > \lambda$*
- *For all $k \geq K$ we have $\delta(A_1, (\rho_1 \cdot \rho_2^{i_2 \cdot k} \cdot \rho_3 \cdot \rho_4^{i_4 \cdot k} \cdot \dots \cdot \rho_{2 \cdot k}^{i_{2 \cdot k} \cdot k})^{2^{|Q|}})(A_1) > 1 - \epsilon$*

Proposition 9. *All simple automata are structurally simple.*

Theorem 3. *The class of simple automata and the class of structurally simple automata coincide.*

5.3 Decision problems for simple automata

For the following of the section, \mathcal{A} is an automaton with state space Q and initial distribution α . Now that we have characterized structurally the class of simple automata, we can show that the *simple automaton problem* of whether a given probabilistic automaton is simple, is a PSPACE complete problem.

Theorem 4. *The simple automaton problem is PSPACE complete.*

We now consider the qualitative decision problems for simple automata. In Proposition 6 of [10], the authors show that if $F \subseteq Q$ is reachable from a state q_0 in the support graph of \mathcal{A} , then it is limit reachable from q_0 in \mathcal{A} . A direct generalization of this result to the extended support graph gives Proposition 10.

Proposition 10. *If F is reachable from $\text{Supp}(\alpha)$ in the extended support graph of \mathcal{A} , then it is limit reachable from α in \mathcal{A} .*

The following Proposition shows that the limit reachability problem is decidable on simple automata, which was the original motivation for the introduction of #-acyclic automata in [10].

Proposition 11. *Let \mathcal{A} be a simple automaton, and let $F \subseteq Q$. Then (1) F is limit reachable in \mathcal{A} iff (2) F is reachable from $\text{Supp}(\alpha)$ in the extended support graph of \mathcal{A} .*

The following proposition provides the decidability of the limit reachability problem on simple automata. Theorem 5 follows using Propositions 12 and 11.

Proposition 12. *Given $S, T \subseteq Q$, we can decide in PSPACE whether there exists a path between S and T in \mathcal{H}_A .*

Theorem 5. *The limit reachability problem is PSPACE-complete on simple automata.*

We consider the complexity of decision problems related to infinite words on simple PAs. The upper bound on the complexity in Proposition 13 follows from the results of Section 4, since the process induced on a simple PA by a word $w \in \Sigma$ is always simple. The lower bound follows from the fact that the PA used for the lower bound of Section 4 is simple. Proposition 14 shows that even the limit parity problem is decidable for simple automata.

Proposition 13. *The almost and positive problems are PSPACE-complete for parity conditions on simple PAs.*

Proposition 14. *The limit problem is PSPACE-complete for parity conditions on simple PAs.*

Theorem 6. *The almost, positive and limit problems are PSPACE-complete on the class of simple automata for the parity condition.*

5.4 Closure properties for Simple Automata

Given $\mathcal{A}_1 = (S_1, \Sigma, \delta_1, \alpha_1)$ and $\mathcal{A}_2 = (S_2, \Sigma, \delta_2, \alpha_2)$ two simple automata on the same alphabet Σ , the construction of the cartesian product automaton $\mathcal{A}_1 \times \mathcal{A}_2$ is standard. We detail this construction in appendix, along with the proof of the following proposition.

Proposition 15. *Let \mathcal{A}_1 and \mathcal{A}_2 be two simple automata. Then $\mathcal{A} = \mathcal{A}_1 \times \mathcal{A}_2$ is also simple.*

We prove that the classes of languages recognized by simple automata under various semantics (positive parity, almost parity) are robust. This property relies on the fact that one can construct the intersection or the union of two parity (non-probabilistic) automata using only product constructions and change in the semantics (going from parity to Streett or Rabin, and back to parity). By Proposition 15, such transformations keep the automata simple.

Theorem 7. *The class languages recognized by simple automata under positive (resp. almost) semantics and parity condition is closed under union and intersection.*

6 Subclasses of Simple Automata

In this section we show that both #-acyclic automata (recall Definition 4) and hierarchical probabilistic automata are strict subclasses of simple automata.

Proposition 16. *The class of simple automata strictly subsumes the class of #-acyclic automata.*

Another restriction of Probabilistic Automata which has been considered is the model of *Hierarchical PAs*, presented first in [6]. Intuitively, a hierarchical PA is a probabilistic automaton on which a *rank function* must increase on every runs. This condition imposes that the induced processes are ultimately deterministic with probability one.

Definition 11 ([6]). *Given $k \in \mathbb{N}$, a PA $\mathcal{B} = (Q, q_s, Q, \delta)$ over an alphabet Σ is said to be a k -level hierarchical PA (k -HPA) if there is a function $\text{rk} : Q \rightarrow \{0, 1, \dots, k\}$ such that the following holds:*

Given $j \in \{0, 1, \dots, k\}$, let $Q_j = \{q \in Q \mid \text{rk}(q) = j\}$. For every $q \in Q$ and $a \in \Sigma$, if $j_0 = \text{rk}(q)$ then $\text{post}(q, a) \subseteq \cup_{j_0 \leq l \leq k} Q_l$ and $|\text{post}(q, a) \cap Q_{j_0}| \leq 1$.

Proposition 17. *The class of simple automata strictly subsumes the class of hierarchical automata.*

It follows that our decidability result (Theorem 6) for simple PAs both unifies and generalizes the decidability results previously known for #-acyclic (for limit reachability) and hierarchical PA (for almost and positive Büchi).

7 Processes Induced by Lasso Shape Words

In this section we consider the decision problems where, instead of restricting the probabilistic automata, we restrict the set of input words to lasso shape words. First, the processes induced by such words are simple:

Proposition 18. *Let \mathcal{A} be a PA, let w be a lasso shape word, and let $\alpha \in \Delta(Q)$. Then the process induced by w and α on Q is simple.*

Corollary 1. *Let \mathcal{M} be a finite state machine. Then for any $w \in \Sigma^\omega$ generated by \mathcal{M} , the process induced by w and α on Q is simple.*

The results of this section along with the results of Section 4 give us the following theorem.

Theorem 8. *Given a probabilistic automaton with parity acceptance condition, the question whether there is lasso shape word that is accepted with probability 1 (or positive probability) is PSPACE-complete.*

Conclusion. In this work we have used a very general result from stochastic processes, namely the decomposition-separation theorem, to identify simple structure of tail σ -fields, and used them to define simple processes on probabilistic automata. We showed that under the restriction of simple processes the almost and positive decision problems are decidable for all parity conditions. We then characterized structurally the class of simple automata on which every process is simple. We showed that this class is decidable, robust, and that it generalizes the previous known subclasses of probabilistic automata for which the decision problems were decidable. Our techniques also show that for lasso shape words the almost and positive decision problems are decidable for all probabilistic automata. We believe that our techniques will be useful in future research for other decidability results related to probabilistic automata and more general probabilistic models.

References

- [1] C. Baier, N. Bertrand, and M. Größer. On decision problems for probabilistic Büchi automata. In *FOSSACS*, pages 287–301. Springer, 2008.
- [2] C. Baier and M. Größer. Recognizing ω -regular languages with probabilistic automata. In *LICS*, pages 137–146, 2005.
- [3] N. Bertrand, B. Genest, and H. Gimbert. Qualitative determinacy and decidability of stochastic games with signals. In *LICS*, pages 319–328, 2009.
- [4] D. Blackwell and D. Freedman. The tail σ -field of a Markov chain and a theorem of Orey. *The Annals of Mathematical Statistics*, 35(3):1291–1295, 1964.
- [5] R. G. Bukharaev. Probabilistic automata. *Journal of Mathematical Sciences*, 13:359–386, 1980.
- [6] R. Chadha, A. Sistla, and M. Viswanathan. Power of randomization in automata on infinite strings. In *CONCUR*, pages 229–243. Springer, 2009.
- [7] K Chatterjee and Thomas A. Henzinger. Probabilistic Automata on Infinite Words: Decidability and Undecidability Results. *ATVA*, 2010.
- [8] H. Cohn. Products of stochastic matrices and applications. *International Journal of Mathematics and Mathematical Sciences*, 12(2):209–233, 1989.
- [9] M. de Rougemont and M. Tracol. Statistic Analysis for Probabilistic Processes. In *LICS*, pages 299–308, 2009.
- [10] H. Gimbert and Y. Oualhadj. Probabilistic automata on finite words: Decidable and undecidable problems. *ICALP*, pages 527–538, 2010.
- [11] V. Gripon and O. Serre. Qualitative concurrent stochastic games with imperfect information. pages 200–211, 2009.
- [12] J.G. Kemeny, J.L. Snell, and A.W. Knapp. *Denumerable markov chains*. Springer, 1976.
- [13] D. Kozen. Lower bounds for natural proof systems. In *FOCS*, pages 254–266, 1977.
- [14] A. Paz. *Introduction to probabilistic automata*. Academic Press, Inc. Orlando, FL, USA, 1971.
- [15] M.O. Rabin. Probabilistic automata. *Information and Control*, 6:230–245, 1963.
- [16] I. Sonin. The asymptotic behaviour of a general finite nonhomogeneous Markov chain (the decomposition-separation theorem). *Lecture Notes-Monograph Series*, 30:337–346, 1996.
- [17] M. Tracol, C. Baier, and M. Grösser. Recurrence and Transience for Probabilistic Automata. In *FSTTCS*, pages 395–409, 2009.
- [18] M.Y. Vardi. Automatic verification of probabilistic concurrent finite state programs. In *FOCS*, pages 327–338, 1985.

Appendix

A Details of Section 3

Details of Proposition 2.

Proof. (of Proposition 2). We present the proof of all three parts below.

Assertion 1. Let $i \in \{1, 2, \dots, c\}$. We prove that τ_∞^i belongs to \mathcal{F}_∞ . We first note that for all $N_0 \in \mathbb{N}$ and $N \geq N_0$, by definition of \mathcal{F}_N , we have $\cap_{n \geq N} \tau_n^i \in \mathcal{F}_{N_0}$. Next, we note that $\{\cap_{n \geq N} \tau_n^i\}_{N \in \mathbb{N}}$ is an increasing sequence of sets of runs, and that the first point of Theorem 1 implies $\tau_\infty^i = \lim_{N \rightarrow \infty} \cap_{n \geq N} \tau_n^i$. For all $N_0 \in \mathbb{N}$, we have \mathcal{F}_{N_0} is a σ -field, hence the limit of an increasing sequences of sets in \mathcal{F}_{N_0} also belong to \mathcal{F}_{N_0} . We get that for all $N_0 \in \mathbb{N}$, we have $\tau_\infty^i \in \mathcal{F}_{N_0}$, hence the result.

Assertion 2. We prove that τ_∞^i is atomic by using Proposition 2.1. of [8], which states the following result:

- For any set Γ in \mathcal{F}_∞ , there exists a sequence L_n of subsets of Q such that, \mathbb{P}^w -almost surely, we have $\lim_{n \rightarrow \infty} \{r \in \Omega \text{ s.t. } r(n) \in L_n\} = \Gamma$.

Here, “ $\lim_{n \rightarrow \infty} \{r \in \Omega \text{ s.t. } r(n) \in L_n\} = \Gamma$ almost surely” means that the \mathbb{P}^w -measure of the set of states on which the characteristic functions of the sets $\{r \in \Omega \text{ s.t. } r(n) \in L_n\}$ and Γ goes to zero as n goes to infinity. For sake of completeness, we prove this fact using the Martingale Convergence Theorem, as in [8] (see for instance [12] for a presentation of the Martingale Convergence Theorem and the Levy’s Law).

Given $n \in \mathbb{N}$, let $\sigma(X_0^w, X_1^w, \dots, X_n^w)$ be the σ -field generated by $X_i^w, i \in \{0, \dots, n\}$. Since Γ belongs to $\mathcal{F}_\infty = \cap_{n \in \mathbb{N}} \mathcal{F}_n$, the Levy’s Law implies that, \mathbb{P}^w almost surely, $\lim_{n \rightarrow \infty} \mathbb{P}(\Gamma | \sigma(X_0^w, X_1^w, \dots, X_n^w)) = 1_\Gamma$, where 1_Γ is the characteristic function of Γ . Since $\{X_n, n \geq 0\}$ is Markovian, we know that for all n we have $\mathbb{P}(\Gamma | \sigma(X_0^w, X_1^w, \dots, X_n^w)) = \mathbb{P}(\Gamma | \sigma(X_n^w))$. Let $0 < \lambda < 1$, and given $n \in \mathbb{N}$ let $L_n = \{q \in Q \mid \mathbb{P}(\Gamma | X_n^w = q) > \lambda\}$. Then, \mathbb{P}^w almost surely, we have $\lim_{n \rightarrow \infty} \{X_n \in L_n\} = \Gamma$, which proves the preliminary result.

Now, let $A \in \tau_\infty^i$. By hypothesis, $\mathbb{P}^w[A] > 0$. Suppose by contradiction that $0 < \mathbb{P}^w[A] < \mathbb{P}^w(\tau_\infty^i)$. Let $B = \tau_\infty^i \setminus A$. We have $A, B \in \mathcal{F}_\infty$, hence there exist $L_n, L'_n, n \in \mathbb{N}$ two sequences of sets such that $\lim_{n \rightarrow \infty} \{r \in \Omega \mid r(n) \in L_n\} = A$ almost surely and $\lim_{n \rightarrow \infty} \{r \in \Omega \mid r(n) \in L'_n\} = B$ almost surely. Let N be large enough, and let $q \in L_N, q' \in L'_N$ be such that :

$$\mathbb{P}[r \in A \mid r(N) = q] > 1 - \frac{1}{4 \cdot |Q|^2};$$

and

$$\mathbb{P}[r \in B \mid r(N) = q'] > 1 - \frac{1}{4 \cdot |Q|^2}.$$

We prove that this contradicts the second point of Theorem 1: first, by the Pigeon Hole Principle, there exists a sequence $q_n, n \geq N$ of states in L'_n such that

$$\lim_n \mathbb{P}[r(n) = q_n \mid r(N) = q'] > \frac{1}{2 \cdot |Q|}.$$

Moreover, by the second point of Theorem 1 we know that

$$\lim_{n \rightarrow \infty} \frac{\mathbb{P}[X_n^w = q_n \mid X_n^w \in J_n^k \wedge X_m^w = q]}{\mathbb{P}[X_n^w = q_n \mid X_n^w \in J_n^k \wedge X_m^w = q']} = 1$$

Thus, for n large enough, $\mathbb{P}[r(n) = q_n \mid r(N) = q] > \frac{1}{4 \cdot |Q|}$. Hence, for n large enough, $\mathbb{P}[r \notin A \mid r(N) = q] > \frac{1}{4 \cdot |Q|^2}$. This is a contradiction.

Assertion 3. The fact that, $\mathbb{P}^w(\bigcup_{i=1}^c \tau_{\infty}^i) = 1$, is a consequence of the first point of Theorem 1: with probability one, after a finite number of steps, a run belongs to one of the J^i and never leaves it. \square

Details of Proposition 3. We prove Proposition 3.

Proof. Let J^0, \dots, J^c be a decomposition of Q^ω into jets, as in Theorem 1. Let $\lambda > 0$ be the threshold given by the definition of a simple process, for the process $\{\mu_n^w\}_{n \in \mathbb{N}}$. For all $i \in \{1, 2, \dots, c\}$ and $n \in \mathbb{N}$, let

$$\widehat{J}_n^i = \{q \in J_n^i \text{ s.t. } \mu_n^w(q) > \lambda\}$$

For all $n \in \mathbb{N}$, let $H_n^0 = J_n^0 \cup \bigcup_{i=1}^c (J_n^i \setminus \widehat{J}_n^i)$, and let $H_n^i = \widehat{J}_n^i$ for $i \in \{1, 2, \dots, c\}$. We claim that the decomposition of Q^ω into jets $H = (H^0, \dots, H^c)$ satisfies the conditions of the proposition.

The first point of the Proposition follows from the definition of the \widehat{J}_n^i . The third point follows from the fact that the process is simple: the probability of the set of states whose measure is less than λ goes to zero. We prove now the second point.

Suppose that there exists no $N \in \mathbb{N}$ such that the property is satisfied for the jet decomposition H . Then, there exists $i \in \{1, 2, \dots, c\}$ such that for all $N \in \mathbb{N}$, there exist $n_2 > n_1 \geq N$ such that $\delta(\widehat{J}_{n_1}^i, w_{n_1}^{n_2}) \not\subseteq \widehat{J}_{n_2}^i$.

We write $w = a_0, a_1, \dots$. Since Q is finite, there exist $i \neq j$ in $\{1, 2, \dots, c\}$ and $q, q' \in Q$ such that for an infinite number of $n \in \mathbb{N}$ we have $q \in \widehat{J}_n^i$, $q' \in \widehat{J}_n^j$, and $\delta(q, a_n)(q') > 0$. Since for n large enough we have $\mu_n^w(q) > \lambda$ for all $q \in \widehat{J}_n^i$, this implies that the probability of the set of runs which move from jet J^i to jet J^j infinitely often is at least $\epsilon \cdot \lambda$, where ϵ is the least non zero probability which appears among the transition probabilities given by the M_a , for $a \in \Sigma$. This implies that the probability of the set of runs which stay inside one of the J^i , $i \in \{1, 2, \dots, c\}$ for ever after a finite number of steps cannot be equal to one. This contradicts the definition of the decomposition J^0, \dots, J^c .

For the fourth point, the fact that the jets are mixing follows directly from the Theorem 1, and the fact that a run does not leave \widehat{J}^i once it has entered it after time N . \square

B Details of Section 4

Details of Proposition 4. We prove Proposition 4.

Proof. By [2] and [7], the almost (resp. positive) safety and reachability problems are decidable for the general class of probabilistic automata, as well as the limit safety problem. The results of [2] and [7] show that if one of the problems is satisfiable, it is satisfiable by a lasso shape word, and hence the simple version of the problem is satisfiable (by the results of our Section 7). As a consequence, we can use this result to get the decidability of the problems when we restrict to simple processes. The PSPACE-completeness follows from the results of [6].

The undecidability of the limit reachability problem comes from the results of [10] and [7], which show that it is undecidable for the general class of probabilistic automata, and from the following fact: Given a PA with state space Q , accepting states $F \subseteq Q$ and $\epsilon \in]0; 1[$, if there exists $w \in \Sigma^\omega$ such that $\mathbb{P}^w[\{r \mid r \in \text{Reach}(F)\}] > 1 - \epsilon$, then there exists $w' \in \Sigma^\omega$ such that $\mathbb{P}^{w'}[\{r \mid r \in \text{Reach}(F)\}] > 1 - 2 \cdot \epsilon$ and the process induced by w' is simple. For this we just have to consider any lasso shape word $w = \rho_1 \cdot \rho_2^\omega$ whose prefix word ρ_1 satisfies the $1 - 2 \cdot \epsilon$ reachability condition. In Section 7, we see that the process induced by a lasso-shape word on an automaton is always simple, which concludes the proof. \square

Details of Proposition 5.

Proof. The proof is in three times: first we present an equivalent formulation of the problem. Then we show that the equivalent formulation gives a problem which we can solve in PSPACE. Finally we give the PSPACE lower bound.

In the following, $p : Q \rightarrow \mathbb{N}$ is a parity function on Q , and $\Phi = \text{Parity}(p)$. We prove that: **(1)** There exists $w \in \Sigma^\omega$ such that the induced process is simple and $\mathbb{P}_A^w(\Phi) = 1$ if and only if **(2)** There exists $G \subseteq Q$ and $\rho_1, \rho_2 \in \Sigma^*$ such that $G = \delta(\alpha, \rho_1)$, $\delta(G, \rho_2) \subseteq G$, and the runs on the Markov chain induced by (G, ρ_2) satisfy Φ with probability one. We show in the appendix that the properties can be verified in PSPACE and also present a PSPACE lower bound.

We show the equivalence **(2)** \Leftrightarrow **(1)**. The way **(2)** \Rightarrow **(1)** is direct, since we will show in Section 7 that the process induced by a lasso shape word on any automaton is always simple. We prove that **(1)** \Rightarrow **(2)**. Let $w = a_1, \dots, a_i, \dots$ be such that the induced process is simple and $\mathbb{P}_A^w(\Phi) = 1$. Using Proposition 3, let J^0, J^1, \dots, J^m be the decomposition of Q^ω into jets and let $N_0 \in \mathbb{N}$, $\lambda > 0$ be such that:

- $\forall n \geq N_0, \forall i \in \{1, 2, \dots, c\}, \forall q \in J_n^i: \mu_n(q) > \lambda$.
- $\forall i \in \{1, 2, \dots, c\}$, for all $n_2 > n_1 \geq N_0$, we have $\delta(J_{n_1}^i, w_{n_1+1}^{n_2}) \subseteq J_{n_2}^i$.
- $\mu_n^w(J_n^0) \xrightarrow{n \rightarrow \infty} 0$
- Each jet J^i , $i \in \{1, 2, \dots, c\}$ is mixing.

Without loss on generality, since Q is finite, taking N_0 large enough, we can assume that the vector of sets of states $(J_{N_0}^0, \dots, J_{N_0}^c)$ appears infinitely often in the sequence $\{(J_n^0, \dots, J_n^c)\}_{n \in \mathbb{N}}$. As well, without loss on generality, we can assume that for all $n \geq N_0$ and all $i \in \{1, 2, \dots, c\}$, all the states in J_n^i appear infinitely often among the sets J_m^i , for $m \geq N_0$. Let $i \in \{1, 2, \dots, c\}$. Given $q \in Q$, let

$$\Phi_q = \{r \in \Omega \mid q \in \text{Inf}(r) \text{ and } p(q) = \min_{q' \in \text{Inf}(r)} p(q')\}$$

Clearly, for all $q \in Q$, $\Phi_q \in \mathcal{F}_\infty$. Since Q is finite, there exists $q_i \in Q$ such that $\mathbb{P}(\tau_\infty^i \cap \Phi_{q_i}) > 0$. By Proposition 2, τ_∞^i is atomic, hence $\tau_\infty^i \subseteq \Phi_{q_i}$. Since the runs of the process satisfy the parity condition with probability one, $p(q_i)$ must be even. Moreover, for all $n \geq N_0$ and all $q \in J_n^i$, we must have $p(q) \geq p(q_i)$. Indeed, such a q appears an infinite number of times in the sequence J_n^i , by hypothesis, and always with probability at least λ .

Since $\tau_\infty^i \subseteq \Phi_{q_i}$, there exists $m_i \in \mathbb{N}$ such that for all $q \in J_i^{N_0}$, there exists $m < m_i$ such that $\delta(q, w[N_0 + 1..m])(q_i) > 0$. We define $m = \max_{i \in \{1, 2, \dots, c\}} m_i$, and $m' \geq m$ such that

$$(J_{N_0}^0, \dots, J_{N_0}^c) = (J_{N_0+m'}^0, \dots, J_{N_0+m'}^c)$$

Taking $\rho_1 = w[0..N_0]$ and $\rho_2 = w[N_0 + 1..N_0 + m']$ completes the proof. Indeed, when starting from the initial distribution, after reading ρ_1 , we arrive by construction in one of the sets $J_{N_0}^i$, with $i \in \{0, \dots, c\}$. Starting from this state q , if the word ρ_2 is taken as input, we go to set $J_{N_0+m'}^i$ with probability one, visit q_i with positive probability, and do not visit any state with probability smaller than $p(q)$. This implies that when starting from q and reading ρ_2^w , we visit q_i with probability one, hence the result.

Now, we argue the PSPACE upper and lower bounds. The proof is close to the proof of the complexity bounds of [17].

First, we show that we can verify the second property in NPSPACE, hence in PSPACE. The proof is in two steps. In a first step, we show that we can decide in NPSPACE whether, given $G \subseteq Q$, there exists $\rho_1 \in \Sigma^*$ such that $G = \delta(\alpha, \rho_1)$. For this notice that, given $G \subseteq Q$, if there exists $\rho_1 \in \Sigma^*$ such that $G = \delta(\alpha, \rho_1)$, then there exists $\rho'_1 \in \Sigma^*$ such that $G = \delta(\alpha, \rho'_1)$ and $|\rho'_1| \leq 2^{|Q|}$. Thus, we can restrict the search to words ρ_1 of length at most $2^{|Q|}$. By guessing the letters a_1, a_2, \dots of ρ_1 one by one, and by keeping in memory the set $A_i = \delta(\alpha, a_1, \dots, a_i)$ at each step, we can check at each step whether $A_i = G$, and thus we can decide whether there exists such a ρ_1 in NPSPACE.

In a second step, we show that, given $G \subseteq Q$, we can decide in NPSPACE whether there exists $\rho_2 \in \Sigma^*$ such that the runs on the periodic non-homogeneous Markov chain induced by (G, ρ_2) satisfy Φ with probability one. For this, we refine the previous argument. Notice that this is equivalent to find $\rho_2 = a_1, \dots, a_k \in \Sigma^*$ and $A, B \subseteq Q$ such that:

- ρ_2 has length at most $2^{2 \cdot |Q|}$
- $\delta(G, \rho_2) \subseteq G$
- A, B partition G
- A is the set of recurrent states for the homogeneous Markov chain induced by ρ_2 on G
- B is the set of transient states for the homogeneous Markov chain induced by ρ_2 on G
- For all $q_0 \in A$, for all the finite runs $q_0, a_1, q_1, a_2, q_2, \dots, a_k$ generated with positive probability when initiated on q and when reading ρ_2 , the minimal value of the $p(q_i)$, $i \in \{0, k-1\}$ is even.

This can be checked in NPSpace. Indeed, we can guess A, B , and the letters of ρ_2 one by one, and at each step keep in memory the following sets:

- The set of states visited at time i , i.e. $E_i = \delta(A \cup B, a_1, \dots, a_i)$
- For all $q \in A$ and all $q' \in \delta(q, a_1, \dots, a_i)$, the minimal p value of the paths visited between q and q' . Notice that this set has size at most $|Q|$.
- For all $q \in A \cup B$ and all $q' \in \delta(A \cup B, a_1, \dots, a_i)$, a boolean value $v_i(q, q')$ which is equal to one if there exists a path between q and q' between the first step and step i , and which is null if not.

At the end, we just have to check that $E_k = G$, that the minimal p -values of all the paths issued from A is even, that the set of states in A are recurrent for the chain, and that the states in B are transient. This can be done easily since we can recover the graph of the Markov chain on G from the values given by v_{ρ_2} .

We prove now that the simple almost Büchi problem is PSPACE-hard. For this, we reduce the problem of checking the emptiness of a finite intersection of regular languages, which is known to be PSPACE complete by [13], to the *simple almost Büchi problem*, which is a particular case of the simple almost parity problem. The size of the input of Problem 1 is the sum of the number of states of the automata.

Problem 1 (Finite Intersection of Regular Languages).

Input: $\mathcal{A}_1, \dots, \mathcal{A}_l$ a family of regular deterministic automata (on finite words) on the same finite alphabet Σ .

Question: Do we have $\mathcal{L}(\mathcal{A}_1) \cap \dots \cap \mathcal{L}(\mathcal{A}_l) = \emptyset$?

Let $\mathcal{A}_1, \dots, \mathcal{A}_l$ be a family of regular automata on the same finite alphabet Σ , with respective state spaces Q and transition functions δ_i (where $\delta_i(s, a)(t) = 1$ if there exist a transition from s to t with label $a \in \Sigma$ in \mathcal{A}_i). We build a probabilistic automaton $\mathcal{A} = (Q, \Sigma', \delta, \alpha, F)$ such that the simple almost Büchi(F) problem is satisfied on \mathcal{A} iff $\mathcal{L}(\mathcal{A}_1) \cap \dots \cap \mathcal{L}(\mathcal{A}_l) \neq \emptyset$.

Let x be a new letter, not in Σ , and let $\Sigma' = \Sigma \cup \{x\}$.

- Q is the union of the state spaces of the \mathcal{A}_i , plus two extra states s and \perp . That is $Q = \bigcup_{i=1}^l Q'_i \cup \{s, \perp\}$, where the Q'_i are disjoint copies of the Q_i .
- The state \perp is a sink: for all $a \in \Sigma'$, $\delta(\perp, a)(\perp) = 1$.
- If u' is the copy of a non accepting state u of \mathcal{A}_i , we allow in \mathcal{A} the same transitions from u' as in \mathcal{A}_i for u : if $a \in \Sigma$, let $\delta(u', a)(v') = 1$ iff v' is the copy of a state $v \in Q_i$ such that $\delta_i(u, a)(v) = 1$. Moreover we add a transition from u with label x : $\delta(u, x)(\perp) = 1$.
- If u' is the copy of an accepting state u of \mathcal{A}_i , $i \in [1; l]$, the transitions from u' in \mathcal{A} are the same as in \mathcal{A}_i , plus an extra transition $\delta(u', x)(s) = 1$.
- From state s in \mathcal{A} , with uniform probability on $i \in [1; l]$, when reading x , the system goes to one of the copies of an initial state of the \mathcal{A}_i 's.
- For the transitions which have not been precised, for instance if $a \in \Sigma$ is read in state s , the system goes with probability one to the sink \perp .
- The initial distribution α is the Dirac distribution on s .
- $F = \{s\}$

Given $\rho \in \mathcal{L}(\mathcal{A}_1) \cap \dots \cap \mathcal{L}(\mathcal{A}_l)$, the input word $(x \cdot \rho \cdot x)^\omega$ satisfies clearly the simple almost Büchi(F) problem since a run visits s after each occurrence of $x \cdot \rho \cdot x$ (the generated process is simple since we see in Section 7 that any process generated on a probabilistic automaton by a lasso shape word is simple).

Conversely, suppose that there exists $\rho \in \Sigma^\omega$ such that the induced process is simple and satisfies almost surely the Büchi(F) condition.

- Since the only transition from s which does not goes to the sink has label x , the word ρ must start with letter x .
- Since with probability one the runs induced by ρ visit infinitely often s , the letter x must appear infinitely often in ρ . Let $\rho = x \cdot \rho' \cdot x$ where $\rho' \in \Sigma$ is non empty and does not contain the letter x . After reading $x \cdot \rho' \cdot x$, since the process cannot be in the sink \perp with positive probability, it has to be on s with probability one. This implies that $\rho' \in \mathcal{L}(\mathcal{A}_1) \cap \dots \cap \mathcal{L}(\mathcal{A}_l)$, hence $\mathcal{L}(\mathcal{A}_1) \cap \dots \cap \mathcal{L}(\mathcal{A}_l) \neq \emptyset$.

This concludes the proof of the PSPACE completeness of our problem. We give an example of the last reduction.

Example 3. Consider the following regular automata \mathcal{A}_1 and \mathcal{A}_2 , and the associated probabilistic automaton \mathcal{A} .

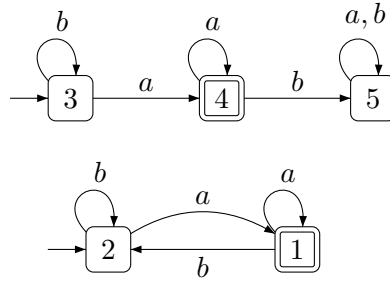

Figure 1. Automata \mathcal{A}_1 and \mathcal{A}_2

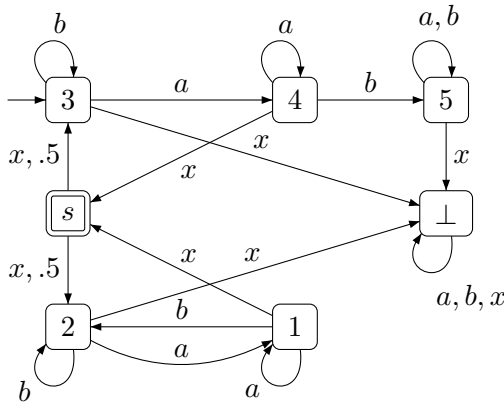

Figure 2. The probabilistic automaton \mathcal{A}

For instance, the word $b \cdot a \cdot a$ belongs to $\mathcal{L}(\mathcal{A}_1) \cap \mathcal{L}(\mathcal{A}_2)$. We get that on \mathcal{A} , the word $(x \cdot b \cdot a \cdot a \cdot x)^\omega$ satisfies the simple almost Büchi($\{s\}$) problem.

This completes the details of the PSPACE upper and lower bound. □

Details of Proposition 6. We prove that the simple positive parity problem is PSPACE-complete.

Proof. As before, let $\Phi = \text{Parity}(p)$ where $p : Q \rightarrow \mathbb{N}$ is a parity function. We follow a method analogous to the one for the simple almost parity problem: We prove that: **(1)** There exists $w \in \Sigma^\omega$ such that the induced process is simple and $\mathbb{P}_{\mathcal{A}}^w(\Phi) > 0$ iff **(2)** There exists $G \subseteq Q$ and $\rho_1, \rho_2 \in \Sigma^*$ such that $G \subseteq \text{Supp}(\delta(\alpha, \rho_1))$, and

$\delta(G, \rho_2) \subseteq G$, and the runs on the Markov chain induced by (G, ρ_2) satisfy Φ with probability one. That is, we reach G with positive probability, and once we read ρ_2 from a state in G we satisfy the condition almost surely.

The way **(2)** \Rightarrow **(1)** of the equivalence is direct. We prove that conversely, **(1)** \Rightarrow **(2)**. Suppose now that there exists such a $w = a_1, \dots, a_i, \dots$. The induced process is simple, so let J^0, J^1, \dots, J^m be as given by Proposition 3. As before, without loss on generality, since Q is finite, we can also assume that the vector of sets $(J_0^{N_0}, \dots, J_c^{N_0})$ appears infinitely often in the sequence (J_n^0, \dots, J_n^c) , $n \in \mathbb{N}$. Moreover, we also assume that for all $n \geq N_0$, for all $i \in \{1, 2, \dots, m\}$, all the states in J_i^n appears in a infinite number of the sets J_i^m , $m \geq N_0$.

Let $i \in \{1, 2, \dots, c\}$. As before, an ultimate property is either satisfied or unsatisfied with probability one by the runs $r \in \Omega$ such that $r(N_0) \in J_i^n$. Thus, we can define $q_i \in Q$ as the state with minimal value for p among the states which are visited infinitely by runs in τ_i^∞ with probability one.

Since the runs of the process satisfy the parity condition with positive probability, there exists $i \in \{1, 2, \dots, c\}$ such that $p(q_i)$ is even. Moreover, for all $n \geq N_0$ and all $q \in J_i^n$, as in the previous case, we must have $p(q) \geq p(q_i)$. Finally, there exists $m_i \in \mathbb{N}$ such that for all $q \in J_i^{N_0}$, there exists $m < m_i$ such that $\delta(q, w[N_0..m])(q_i) > 0$. We define $m' \geq m_i$ such that

$$(J_{N_0}^0, \dots, J_{N_1}^c) = (J_{N_0+m'}^0, \dots, J_{N_0+m'}^c)$$

Taking $\rho_1 = w[0..N_0]$ and $\rho_2 = w[N_0..N_0 + m']$ concludes the proof.

The PSPACE upper and lower bound proofs are analogous to the proof of Proposition 5. □

Details of Proposition 7. We prove that the simple limit Büchi and coBüchi problems are undecidable.

Proof. This is a direct consequence of the fact that the simple limit reachability problem is undecidable. The reduction from an instance of the simple limit reachability problem is direct: we only delete all outgoing transitions from the accepting states in F , and transform them into self loops for all label $a \in \Sigma$. We get a probabilistic automaton on which the simple limit Büchi and coBüchi problems are satisfied iff the simple limit reachability problem is satisfied. □

C Details of Section 5

Details of Lemma 1. We prove Lemma 1.

Proof. Notice first that by definition, every cycle in \mathcal{H}_A contains a cycle which is elementary. Thus, we just have to show that seq contains a cycle. If $A_{k+1} = A_1$, then we are done. If $A_{k+1} \subsetneq A_1$, let B_1 be such that $A_{k+1} \xrightarrow{\rho_1 \rho_2^\#} \dots \xrightarrow{\rho_k} B_1$. Then we have $B_1 \subseteq A_{k+1}$. If $B_1 = A_{k+1}$ then we are done, since $B_1 \xrightarrow{\rho_1 \rho_2^\#} \dots \xrightarrow{\rho_k} B_1$ is a subpath of seq which is a cycle. If $B_1 \subsetneq A_{k+1}$, then we continue the construction iteratively: for $i \geq 1$, until we find B_{i+1} such that $B_i = B_{i+1}$, we let B_{i+1} be such that $B_i \xrightarrow{\rho_1 \rho_2^\#} \dots \xrightarrow{\rho_k} B_{i+1}$. By construction at each step we have $B_i \neq \emptyset$, and $B_{i+1} \subseteq B_i$. Clearly, the construction has to stop after at most $|Q|$ steps, and we get a cycle $B_i \xrightarrow{\rho_1 \rho_2^\#} \dots \xrightarrow{\rho_k} B_i$ which is a subpath of seq . □

Details of Lemma 2. We prove the key Lemma 2.

Proof. Given $U \subseteq Q$ and $\rho \in \Sigma^*$, let

$$\delta^{-1}(\rho)(U) = \{q \in Q \mid \delta(q, \rho)(U) > 0\}$$

The following remark will be useful: given $\rho = a_1, \dots, a_n \in \Sigma^*$, given $U \subseteq Q$ and $i \in \{0, 1, 2, \dots, n-1\}$, let $S_i = \delta^{-1}(a_{i+1}, \dots, a_n)(U)$. Then we have:

1. For all $i \in \{0, 1, 2, \dots, n-1\}$, $\delta(Q \setminus S_i, a_{i+1}, \dots, a_n) \subseteq Q \setminus U$
2. For all $i \in \{0, 1, 2, \dots, n-2\}$, if $\delta(S_i, a_{i+1}) \subseteq S_{i+1}$, then $\delta(\alpha, a_1, \dots, a_i)(S_i) = \delta(\alpha, a_1, \dots, a_{i+1})(S_{i+1})$
3. Given $i \in \{0, 1, 2, \dots, n-2\}$, let k_i be the number of integers $j \in [i; n-2]$ such that $\delta(S_j, a_{j+1}) \not\subseteq S_{j+1}$.
Then, for all $i \in \{0, 1, 2, \dots, n-2\}$,

$$\delta(\alpha, a_1, \dots, a_n)(U) \geq \delta(\alpha, a_1, \dots, a_i)(S_i) \cdot \epsilon^{k_i}$$

The only non trivial point is the last one. It follows from the fact that for all $\rho \in \Sigma^*$ and $q, q' \in Q$, if $\delta(q, \rho)(q') > 0$, then by definition of ϵ we have $\delta(q, \rho)(q') > \epsilon^{|\rho|}$.

By contradiction, suppose that there exists $\rho \in \text{CRec}(q)$ and $U \subseteq Q$ such that $U \subseteq \text{Supp}(\delta(q, \rho))$ and

$$\delta(q, \rho)(U) < \epsilon^{2^{2 \cdot |Q|}}$$

We show that then we can write $\rho = \rho_1 \cdot \rho_2 \cdot \rho_3$ where ρ_1, ρ_2, ρ_3 are such that $\delta(q, \rho_1)$ can be partitioned into two subsets A and B such that (A, B, ρ_2) is a leak. This contradicts the definition of $\text{CRec}(A)$.

Let $\rho = a_1, \dots, a_l$. Given $i \in \{0, 1, 2, \dots, l-1\}$, let:

- $V_i^n = \delta^{-1}(a_{i+1}, a_{i+2}, \dots, a_l)(U) \cap \delta(q, a_1, \dots, a_i)$
- $W_i^n = (Q \setminus V_i^n) \cap \delta(q, a_1, \dots, a_i)$

Using the fifth point of the previous remark, since $\delta(q, \rho)(U) < \epsilon^{2^{2 \cdot |Q|}}$, there exists a least k integers i in $\{1, 2, \dots, l-2\}$ such that $\delta(V_i^n, a_{i+1}) \not\subseteq V_{i+1}^n$, where k satisfies $\epsilon^k < \epsilon^{2^{2 \cdot |Q|}}$. Thus, $k \geq 2^{2 \cdot |Q|}$. Let $n_1, \dots, n_{2^{2 \cdot |Q|}}$ be the $2^{2 \cdot |Q|}$ largest integers in $\{1, 2, \dots, l\}$ such that $\delta(V_{n_i}^n, a_{n_i+1}) \not\subseteq V_{n_i+1}^n$.

By a simple cardinality argument, there exist $i < j$ in $\{1, 2, \dots, 2^{2 \cdot |Q|}\}$ such that $V_{n_i}^n = V_{n_j}^n$ and $W_{n_i}^n = W_{n_j}^n$. Let $\rho_1 = a_1, \dots, a_{n_i-1}$, $\rho_2 = a_{n_i}, \dots, a_{n_j-1}$ and $\rho_3 = a_{n_j}, \dots, a_n$. Then we are in the following situation:

$$\begin{array}{ccccc} q & \xrightarrow{\rho_1} & W_{n_i}^n & \xrightarrow{\rho_2} & W_{n_i}^n \\ & \searrow \rho_1 & & \nearrow \rho_2 & \\ & & V_{n_i}^n & \xrightarrow{\rho_2} & V_{n_i}^n \end{array}$$

That is, $\delta(q, \rho_1)$ can be partitioned into two subsets $V_{n_i}^n$ and $W_{n_i}^n$ such that $\delta(W_{n_i}^n, \rho_2) \subseteq W_{n_i}^n$, $\delta(V_{n_i}^n, \rho_2) \subseteq V_{n_i}^n \cup W_{n_i}^n$, and $\delta(V_{n_i}^n, \rho_2) \not\subseteq V_{n_i}^n$. This implies that there exists $A \subseteq V_{n_i}^n$ such that $(A, (V_{n_i}^n \setminus A) \cup W_{n_i}^n, \rho_2)$ is a leak. Since $A, (V_{n_i}^n \setminus A) \cup W_{n_i}^n$ is a partition of $\delta(q, \rho_1)$, we get that the execution tree (q, ρ) contains a leak. This is a contradiction since $\rho \in \text{CRec}(q)$. \square

Details of Lemma 3.

We start with a remark, and a preliminary lemma.

Remark 1. Given a structurally simple automaton \mathcal{A} , an elementary cycle with no $\#$ -edge can be rewritten as $C = A_1 \xrightarrow{\rho_1} A_2 \xrightarrow{\rho_2} \dots \xrightarrow{\rho_k} A_{k+1} = A_1$. Given $\rho = \rho_1 \cdot \rho_2 \cdot \dots \cdot \rho_k$, we associate the couple (A_1, ρ) to the cycle C .

Notice that for any decomposition $\rho = \rho'_1 \cdot \rho'_2 \cdot \dots \cdot \rho'_k$ of ρ , the cycle $C' = A_1 \xrightarrow{\rho'_1} A'_2 \xrightarrow{\rho'_2} \dots \xrightarrow{\rho'_k} A'_{k+1} = A_1$ is also an elementary cycle.

Lemma 9. Suppose that \mathcal{A} is structurally simple, and let (E, ρ) be associated to an elementary cycle of \mathcal{A} as in remark 1. Then (E, ρ) is a chain recurrent execution tree.

Proof. Suppose by contradiction that (E, ρ) is not chain recurrent. Then there exists $\rho_1, \rho_2, \rho_3 \in \Sigma^*$ and $A, B \subseteq Q$ non empty such that $\rho = \rho_1 \cdot \rho_2 \cdot \rho_3$, $A \cap B = \emptyset$, $A \cup B = \delta(E, \rho_1)$, $A \cup B = (A \cup B) \cdot \rho_2$ and $B = (A \cup B) \cdot \rho_2^\#$. Notice that since (E, ρ) is elementary, $\text{seq} = E \xrightarrow{\rho_1} A \cup B \xrightarrow{\rho_2} A \cup B \xrightarrow{\rho_3} E$ is also elementary. Then, $\text{seq}' = E \xrightarrow{\rho_1} A \cup B \xrightarrow{\rho_2^\#} B \xrightarrow{\rho_3} \delta(B, \rho_3)$ is a path in $\mathcal{H}_{\mathcal{A}}$. Since $\delta(B, \rho_3) \subseteq \delta(A \cup B, \rho_3) = E$, by Lemma

1, the path seq' contains an elementary cycle $seq'' = C_1 \xrightarrow{\rho_1} C_2 \xrightarrow{\rho_2^\#} C_3 \xrightarrow{\rho_3} C_1$. Since \mathcal{A} is structurally simple, the sequence $C_2 \xrightarrow{\rho_2^\#} C_3$ is not a $\#$ -reduction, i.e. we must have $C_2 = C_2 \cdot \rho_2^\# = C_3$, hence also $C_2 = C_2 \cdot \rho_2 = C_3$. This proves that $seq''' = C_1 \xrightarrow{\rho_1} C_3 \xrightarrow{\rho_2} C_3 \xrightarrow{\rho_3} C_1$ is a subcycle of seq . But by construction we have that $C_3 \subseteq B$, hence $C_3 \neq A \cup B$. Thus, seq''' is a subcycle of seq different from seq . This contradicts the fact that seq is elementary. \square

We now prove Lemma 3.

Proof. The proof is direct: by Lemma 1, the path $A \xrightarrow{\rho} A \cdot \rho$ contains an elementary cycle $B \xrightarrow{\rho} B$. By Lemma 9, (B, ρ) is chain recurrent. \square

Details of Lemma 4. We prove Lemma 4.

Proof. For all $n \in \mathbb{N}$, we let $A_n = \text{Supp}(\delta(\alpha, w[1..n]))$ and $B_n = Q \setminus A_n$. By hypothesis, for all $n \geq N$ and all $q \in A_n$, we have $\mu_n^w(q) = \delta(\alpha, w[1..n])(q) > \gamma$. Moreover, for all n and all $q \in B_n$ we have $\mu_n^w(q) = 0$. This shows that the process is simple. \square

Details of Lemma 5. We prove Lemma 5.

Proof. Let $\rho \in \Sigma^\omega$, and let $\{\mu_n^\rho\}_{n \in \mathbb{N}}$ be the process induced on Q by ρ . By hypothesis, let $(\alpha, \rho_1), \rho'_1, (\alpha_2, \rho_2), \rho'_2, \dots, (\alpha_k, \rho_k)$ be a subsequence of recurrent execution trees of (α, ρ) of length at most K . That is, we have $\sum_{i=1}^{k-1} |\rho'_i| \leq K$. By definition, for all $i \in \{1, \dots, k-1\}$ we have $\rho_i \in \Sigma^*$ and $\rho'_i \in \Sigma^*$, and $\rho_k \in \Sigma^\omega$.

For all $i \in \{1, \dots, k-1\}$, let $\alpha'_i = \delta(\alpha_i, \rho_i)$. We are in the following situation:

$$\alpha \xrightarrow{\rho_1} \alpha'_1 \xrightarrow{\rho'_1} \alpha_2 \xrightarrow{\rho_2} \alpha'_2 \xrightarrow{\rho'_2} \alpha_3 \dots \xrightarrow{\rho'_{k-1}} \alpha_k \xrightarrow{\rho_k}$$

We know that:

- For all $i \in \{1, \dots, k-2\}$, the execution tree (α_i, ρ_i) is chain recurrent
- (α_k, ρ_k) is chain recurrent

We show that the process $\{\mu_n^\rho\}_{n \in \mathbb{N}}$ satisfies the hypothesis of Lemma 4. As before, let $\epsilon = \epsilon(\mathcal{A})$ be the minimal non zero probability which appears among the values $\delta(q, a)(q)$ when $q, q' \in Q$ and $a \in \Sigma$. Let $\lambda = \epsilon^{2 \cdot |Q|}$. By Lemma 2, for all $q \in Q$, all $\rho' \in \text{CRec}(q)$ and all $q' \in \text{Supp}(\delta(q, \rho'))$, we have $\delta(q, \rho')(q') \geq \lambda$. We claim that for all $i \in \{1, \dots, k-1\}$ and all $q \in \text{Supp}(\alpha'_i)$, we have $\alpha'_i(q) \geq (\text{Min}_{q \in \text{Supp}(\alpha)} \alpha(q)) \cdot \lambda^i \cdot \epsilon^{K \cdot i}$. We prove this result by induction on i :

- The case $i = 1$ follows from the use of Lemma 2 on the chain recurrent execution tree (α_1, ρ_1) .
- Suppose the proposition true until $i \in \{1, \dots, k-2\}$. Let $q' \in \text{Supp}(\alpha'_{i+1})$. then there exists $q \in \text{Supp}(\alpha'_i)$ such that $\delta(q, \rho_i \cdot \rho'_i)(q') > 0$. Let $q'' \in Q$ be such that $\delta(q, \rho_i)(q'') > 0$, and $\delta(q'', \rho'_i)(q') > 0$. By the use of Lemma 2 on the chain recurrent execution tree (α_i, ρ_i) , we know that $\delta(q, \rho_i)(q'') > \lambda$. By definition of ϵ and K , we have that $\delta(q'', \rho'_i)(q') \geq \epsilon^{|\rho'_i|}$, hence $\delta(q'', \rho'_i)(q') \geq \epsilon^K$. We have $\alpha'_{i+1}(q') \geq \alpha_i(q) \cdot \delta(q, \rho_i \cdot \rho'_i)(q')$. Since by induction hypothesis we have that $\alpha_i(q) \geq (\text{Min}_{q \in \text{Supp}(\alpha)} \alpha(q)) \cdot \lambda^i \cdot \epsilon^{K \cdot i}$, we get that $\alpha'_{i+1}(q') \geq (\text{Min}_{q \in \text{Supp}(\alpha)} \alpha(q)) \cdot \lambda^{i+1} \cdot \epsilon^{K \cdot i+1}$, hence the result.

Now, let $N = \sum_{i=1}^{k-1} (|\rho_i| + |\rho'_i|)$, and let $n \geq N$. Since (α_k, ρ_k) is chain recurrent, we can apply the same method for the chain recurrent execution tree (α_k, ρ_k) . As a conclusion, we see that the process $\{\mu_n^\rho\}_{n \in \mathbb{N}}$ satisfies the hypothesis of Lemma 4 with the parameters $N = \sum_{i=1}^{k-1} (|\rho_i| + |\rho'_i|)$ and $\gamma = (\text{Min}_{q \in \text{Supp}(\alpha)} \alpha(q)) \cdot \lambda^K \cdot \epsilon^{K \cdot K}$. This proves the result. \square

Details of Lemma 6. We prove Lemma 6.

Proof. Let $\rho = \rho_1 \cdot \rho_2 \cdot \dots \cdot \rho_{2 \cdot k - 1}$ be the decomposition of ρ into subwords such that

$$A \xrightarrow{\rho_1} \xrightarrow{\rho_2^\#} \xrightarrow{\rho_3} \xrightarrow{\rho_4^\#} \dots \xrightarrow{\rho_{2 \cdot k - 1}} B$$

By Lemma 1, this path contains an elementary cycle:

$$C_1 \xrightarrow{\rho_1} C_2 \xrightarrow{\rho_2^\#} C_3 \xrightarrow{\rho_3} C_4 \xrightarrow{\rho_4^\#} \dots \xrightarrow{\rho_{2 \cdot k}^\#} C_1$$

Since \mathcal{A} is structurally simple, the cycle does not contain any $\#$ -reduction, hence for all $i \in \{1, \dots, 2 \cdot k\}$ which is even, we have $C_i = C_i \cdot \rho_i^\#$, and then also $C_i = C_i \cdot \rho_i$. By Lemma 9, this implies that (C_1, ρ) is chain recurrent. \square

Details of Lemma 7. We prove Lemma 7.

Proof. We build iteratively the following sequences $\{A_i\}_{i \in \mathbb{N}}, \{A'_i\}_{i \in \mathbb{N}}, \{B_i\}_{i \in \mathbb{N}}, \{\rho_i\}_{i \in \mathbb{N}}, \{\rho'_i\}_{i \in \mathbb{N}}, \{a_i\}_{i \in \mathbb{N}}, \{w_i\}_{i \in \mathbb{N}}$:

- Let $A_1 = \text{Supp}(\alpha)$, and $B_1 = \emptyset$.
- ρ_1 is the longest prefix of w such that there exists $A'_1 \subseteq Q$ such that $A_1 \xrightarrow{\#-\rho_1} A'_1$, and $A'_1 \subseteq A_1$. If the set of valid word is not bounded, then we let $\rho_1 = w$ and the construction stops.
- Let w_1 be such that $\rho_1 \cdot w_1 = w$.
- If the execution tree (A'_1, w_1) is chain recurrent, we stop the construction. If not, let ρ'_1 of maximal length be such that (A'_1, ρ'_1) is chain recurrent.
- Let $a_1 \in \Sigma$ be the letter which follows $\rho_1 \cdot \rho'_1$ in w . By construction, $(A'_1, \rho'_1 \cdot a_1)$ is not chain recurrent, hence we can decompose $\rho'_1 \cdot a_1$ as $\rho'_1 \cdot a_1 = \rho''_1 \cdot \rho'''_1$ and find U_1, V_1 a partition of $\delta(A'_1, \rho''_1)$ such that (U_1, V_1, ρ'''_1) is a leak and $U_1 \cup V_1 = \delta(A'_1, \rho''_1) = \delta(A'_1, \rho'_1 \cdot a_1)$. We let $A_2 = V_1$. Remark that $A'_1 \xrightarrow{\#-\rho'_1 \cdot a_1} A_2$. Since $A_1 \xrightarrow{\#-\rho_1} A'_1$, this implies that $A_1 \xrightarrow{\#-\rho_1 \cdot \rho'_1 \cdot a_1} A_2$. By definition of A'_1 , we have $A_2 \neq A_1$.
- Let $B_2 = \delta(A_1, \rho_1 \cdot \rho'_1 \cdot a_1) \setminus A_2$.
- Let $i \geq 1$. Suppose that we have constructed the sets $A_1, B_1, A'_1, \dots, A_{i+1}, B_{i+1}$, and the sequence of finite words $\rho_1, w_1, \rho'_1, a_1, \rho''_1, \dots, \rho_i, w_i, \rho'_i, a_i, \rho''_i$. We continue the construction as follows:
 - ρ_{i+1} is the longest prefix of w_i such that there exists $A'_{i+1} \subseteq Q$ such that $A_{i+1} \xrightarrow{\#-\rho_{i+1}} A'_{i+1}$, and $A'_{i+1} \subseteq A_{i+1}$. If the set of available words is not bounded, then we let $\rho_{i+1} = w_i$ and the construction stops.
 - Let w_{i+1} be such that $\rho_1 \cdot \rho'_1 \cdot \rho''_1 \cdot \dots \cdot \rho_{i+1} \cdot w_{i+1} = w$.
 - If the execution tree (A'_{i+1}, w_{i+1}) is chain recurrent, we stop the construction. If not, let ρ'_{i+1} of maximal length be such that (A'_{i+1}, ρ'_{i+1}) is chain recurrent.
 - Let $a_{i+1} \in \Sigma$ be the letter which follows $\rho_1 \cdot \rho'_1 \cdot \dots \cdot \rho_{i+1} \cdot \rho'_{i+1}$ in w . By construction, $(A'_{i+1}, \rho'_{i+1} \cdot a_{i+1})$ is not chain recurrent, hence we can decompose $\rho'_{i+1} \cdot a_{i+1}$ as $\rho'_{i+1} \cdot a_{i+1} = \rho''_{i+1} \cdot \rho'''_{i+1} \cdot \rho''''_{i+1}$ and find U_{i+1}, V_{i+1} a partition of $\delta(A'_{i+1}, \rho''_{i+1})$ such that $(U_{i+1}, V_{i+1}, \rho''''_{i+1})$ is a leak and $U_{i+1} \cup V_{i+1} = \delta(A'_{i+1}, \rho''_{i+1}) = \delta(A'_{i+1}, \rho'_{i+1} \cdot a_{i+1})$. We let $A_{i+2} = V_{i+1}$. Remark that $A'_{i+1} \xrightarrow{\#-\rho'_{i+1} \cdot a_{i+1}} A_{i+2}$. Since by induction we have $A_1 \xrightarrow{\#-\rho_1} A_{i+1}$ and since by hypothesis $A_{i+1} \xrightarrow{\#-\rho_{i+1}} A'_{i+1}$, this implies that $A_1 \xrightarrow{\#-\rho_1 \cdot \rho'_1 \cdot a_1 \cdot \dots \cdot \rho'_{i+1} \cdot a_{i+1}} A_{i+2}$. By definition of A'_{i+1} , we have $A_{i+2} \neq A_{i+1}$, and by induction we have $A_{i+2} \neq A_j$ for all $j \leq i + 1$.
 - Let $B_{i+2} = \delta(A_1, \rho_1 \cdot \rho'_1 \cdot a_1 \cdot \dots \cdot \rho_{i+1} \cdot \rho'_{i+1} \cdot a_{i+1}) \setminus A_{i+1}$.

Since there exists at most $2^{|Q|}$ different subsets A_i of Q , the construction stops after at most $2^{|Q|}$ steps. We get a sequence:

$$A_1 \xrightarrow{\rho_1} \xrightarrow{\rho'_1} \xrightarrow{a_1} \dots \xrightarrow{\rho_i} \xrightarrow{\rho'_i} \xrightarrow{a_i} A_{i+1} \xrightarrow{\rho_{i+1}}$$

Where $\rho_{i+1} \in \Sigma^\omega$. Moreover, we now by construction that $\rho_{i+1} = w_i$, since by hypothesis the set of prefixes ρ_{i+1} of w_i such that there exists $A'_{i+1} \subseteq Q$ such that $A_{i+1} \xrightarrow{\# \cdot \rho_{i+1}} A'_{i+1}$ and $A'_{i+1} \subseteq A_{i+1}$ is not bounded. We can use Lemma 6 iteratively to show that this imply that there exists $C \subseteq A_{i+1}$ such that (C, ρ_{i+1}) is chain recurrent. Indeed, by Lemma 6, to any finite length prefix $pref$ of w_i such that there exists $A'_{i+1} \subseteq Q$ such that $A_{i+1} \xrightarrow{\# \cdot pref} A'_{i+1}$ and $A'_{i+1} \subseteq A_{i+1}$, we can associate $C_{pref} \subseteq A_{i+1}$ such that $(A_{i+1}, pref)$ is chain recurrent. Taking $C \subseteq A_{i+1}$ which appears infinitely often among the C_{pref} concludes the point.

By Lemma 6, for all i , $A_i \xrightarrow{\rho_i} A'_i$ is such that we can find $B_i \subseteq A_i$ such that (B_i, ρ_i) is chain recurrent. Since for all i we have that $A'_i \xrightarrow{\rho'_i} A_{i+1}$ is chain recurrent by construction, we get a subsequence of recurrent execution trees of (α, w) of length at most $2^{|Q|}$ (only the subsequences which correspond to arrows $\xrightarrow{a_i}$ may not contain a chain recurrent subsequence). \square

Details of Lemma 8. We prove Lemma 8.

Proof. We define the following set of distributions $\alpha_1, \alpha_2, \dots, \alpha_{2 \cdot k}$ on Q :

- α_1 is the uniform distribution on A_1
- $\alpha_2 = \delta(\alpha_1, \rho_1)$. We have in particular $A_2 \subseteq \text{Supp}(\alpha_2)$.
- Let $i_2 \geq 1$ and $\lambda_2 > 0$ be such that for all state q' of Q which is recurrent for ρ_2 and which is reachable from a state q in $\text{Supp}(\alpha_1)$ we have $\delta(q, \rho_2^{i_2})(q') > \lambda_2$. Then we let $\alpha_3 = \delta(\alpha_2, \rho_2^{i_2})$. By construction, $A_3 \subseteq \text{Supp}(\alpha_3)$.
- From $j = 2$ until $j = k$ we do the following step iteratively:
 - $\alpha_{2 \cdot j} = \delta(\alpha_{2 \cdot j - 1}, \rho_{2 \cdot j - 1})$. We have $A_{2 \cdot j} \subseteq \text{Supp}(\alpha_{2 \cdot j})$.
 - Let $i_{2 \cdot j} \geq 1$ and $\lambda_{2 \cdot j} > 0$ be such that for all state q' of Q which is recurrent for $\rho_{2 \cdot j}$ and which is reachable from a state q in $\text{Supp}(\alpha_{2 \cdot j - 1})$ we have $\delta(q, \rho_{2 \cdot j}^{i_{2 \cdot j}})(q') > \lambda_{2 \cdot j}$. Then we let $\alpha_{2 \cdot j + 1} = \delta(\alpha_{2 \cdot j}, \rho_{2 \cdot j}^{i_{2 \cdot j}})$. Again, by construction, $A_{2 \cdot j + 1} \subseteq \text{Supp}(\alpha_{2 \cdot j + 1})$

Finally, we define the following bipartite graph $link(seq)$ on A_1 : given $q, q' \in A_1$, the edge (q, q') belongs to $link(seq)$ iff we have

$$\delta(q, (\rho_1 \cdot \rho_2^{i_2} \cdot \rho_3 \cdot \rho_4^{i_4} \cdot \dots \cdot \rho_{2 \cdot k}^{i_{2 \cdot k}}))(q') > 0$$

Since the cycle seq is supposed to be elementary, the graph $link(seq)$ must be connected. That is, given $q, q' \in A_1$, there must exists a sequence of edges $(q_1, q_2), (q_2, q_3), \dots, (q_{i-1}, q_i)$ in $link(seq)$ such that $q = q_1$ and $q' = q_i$. If it were not the case, we could build a subcycle of seq . Now, by a simple cardinality argument, if $link(seq)$ is connected, then given $q, q' \in A_1$, there must exists a sequence of edges $(q_1, q_2), (q_2, q_3), \dots, (q_{i-1}, q_i)$ in $link(seq)$ such that $q = q_1$ and $q' = q_i$, and such that $i \leq 2^{|Q|}$. But this implies that for all $q, q' \in A_1$ we have:

$$\delta(q, (\rho_1 \cdot \rho_2^{i_2 \cdot k} \cdot \rho_3 \cdot \rho_4^{i_4 \cdot k} \cdot \dots \cdot \rho_{2 \cdot k}^{i_{2 \cdot k} \cdot k})^{2^{|Q|}})(q') > 0$$

Hence the result.

Moreover, we can check that by construction of the i_j , we get that for all $q, q' \in A_1$ and all $k \geq 2^{|Q|}$ we have

$$\delta(q, (\rho_1 \cdot \rho_2^{i_2 \cdot k} \cdot \rho_3 \cdot \rho_4^{i_4 \cdot k} \cdot \dots \cdot \rho_{2 \cdot k}^{i_{2 \cdot k} \cdot k})^{2^{|Q|}})(q') > \prod_{j=1}^k \lambda_{2 \cdot j}$$

The second point follows from the fact that for all $j \in \{1, \dots, k-1\}$ we have $A_{2 \cdot j} \cdot \rho_{2 \cdot j}^\# = A_{2 \cdot j + 1}$ \square

Details of Proposition 9. We prove Proposition 9.

Proof. We prove the contraposition of the proposition: let \mathcal{A} be a probabilistic automaton such that $\mathcal{H}_{\mathcal{A}}$ contains an elementary cycle with a $\#$ -reduction. We show that \mathcal{A} is not simple. Let

$$C = A_1 \xrightarrow{\rho_1} A_2 \xrightarrow{\rho_2^\#} A_3 \dots \xrightarrow{\rho_k} A_1$$

be an elementary cycle in $\mathcal{H}_{\mathcal{A}}$ where $A_2 \xrightarrow{\rho_2^\#} A_3$ is a $\#$ -reduction. Let $\epsilon > 0$ be the minimal values which appears among the non zero values of the $\delta(q, a)(q')$, when $q, q' \in Q$ and $a \in \Sigma$. Let i_2, i_4, \dots , be given by Lemma 8. For all $i \geq 1$, let $k_i \in \mathbb{N}$ be the smallest integer such that $\delta(A_1, (\rho_1 \cdot \rho_2^{i_2 \cdot k} \cdot \rho_3 \cdot \rho_4^{i_4 \cdot k} \cdot \dots \cdot \rho_k)^{2^{|\mathcal{Q}|}})(A_1) > 1 - \frac{1}{2^i}$. We consider the process generated on \mathcal{A} be the word w equal to:

$$(\rho_1 \cdot \rho_2^{i_2 \cdot k_1} \cdot \rho_3 \cdot \rho_4^{i_4 \cdot k_1} \cdot \dots \cdot \rho_{k_1})^{2^{|\mathcal{Q}|}} \cdot (\rho_1 \cdot \rho_2^{k_2} \cdot \rho_3 \cdot \rho_4^{k_2} \cdot \dots \cdot \rho_{k_2})^{2^{|\mathcal{Q}|}} \cdot \dots$$

We claim that this process is not simple. By hypothesis, $A_2 \xrightarrow{\rho_2^\#} A_3$ is a $\#$ -reduction in $\mathcal{H}_{\mathcal{A}}$. Thus, $A_3 \subseteq A_2$, and there exists $q' \in A_2 \setminus A_3$. Given $i \geq 2$, let $\sigma_i \in \Sigma^*$ be such that $\sigma_i = (\rho_1 \cdot \rho_2^{k_1} \cdot \rho_3 \cdot \rho_4^{k_1} \cdot \dots \cdot \rho_{k_1})^{2^{|\mathcal{Q}|}} \cdot (\rho_1 \cdot \rho_2^{k_2} \cdot \rho_3 \cdot \rho_4^{k_2} \cdot \dots \cdot \rho_{k_2})^{2^{|\mathcal{Q}|}} \cdot \dots \cdot (\rho_1 \cdot \rho_2^{k_{i-1}} \cdot \rho_3 \cdot \rho_4^{k_{i-1}} \cdot \dots \cdot \rho_{k_{i-1}})^{2^{|\mathcal{Q}|}} \cdot \rho_1$.

Let $\lambda > 0$ be given by Lemma 8. By Lemma 8 and by construction of the k_i , for all $i \geq 1$ and $q \in A_1$, we have that $\delta(q, \sigma_i)(q') > \lambda \cdot \epsilon$. That is, $\mu_{|\sigma_i|}^w(q') > \lambda \cdot \epsilon$. However, since $|k_i|$ goes to infinity, and since $q' \in A_2 \setminus A_3$, for all $\gamma > 0$, there exists $i \in \mathbb{N}$ such that $0 < \delta(q, \rho_2^{k_i})(q') < \gamma$. This is in contradiction with the definition of a simple process. Thus the process is not simple. \square

Details of Theorem 4. We prove Theorem 4.

Proof. The proof follows the same lines as the other complexity proofs of this paper. We first show that the problem is in NPSPACE, hence in PSPACE, and next prove that the problem is PSPACE hard by a reduction from the *intersection of regular automata problem*.

First, we have to show that the following problem is in PSPACE: given a probabilistic automaton \mathcal{A} , does $\mathcal{H}_{\mathcal{A}}$ contain an elementary cycle with a $\#$ -reduction. If such a cycle $C = A_1 \xrightarrow{\rho_1'} A_2 \xrightarrow{\rho_2^\#} A_3 \xrightarrow{\rho_3'} A_4 \xrightarrow{\rho_4^\#} A_5 \dots \xrightarrow{\rho_{k'}} A_1$ exists, notice that we can find another elementary cycle $C' = A_1 \xrightarrow{\rho_1} A_2 \xrightarrow{\rho_2^\#} A_3 \xrightarrow{\rho_3} A_4 \xrightarrow{\rho_4^\#} A_5 \dots \xrightarrow{\rho_k} A_1$ such that $k \leq 2^{2 \cdot |\mathcal{Q}|}$. Indeed, we can get rid of the internal repetition of sets in the cycle, as long as we keep the structure of the underlying connexion graph. Next, recall the definition of the bipartite graph $link(C)$ presented in Lemma 8. Then the following problem is in PSPACE: given $B \subseteq A \subseteq Q$ and I a bipartite graph on A , decide whether there exists $\rho \in \Sigma^*$ such that $A \cdot \rho = B$, $A \cdot \rho^\# = A$, and $link(A, \rho) = I$. For this, we just guess the letters of ρ one by one, and keep in memory the partial link graphs. Finally, to decide whether $\mathcal{H}_{\mathcal{A}}$ contains an elementary cycle with a $\#$ -reduction, we just use the two previous remarks to guess the intermediate sets on by one. Keeping the partial link graph in memory, we can check the result in NPSPACE, hence in PSPACE.

To show that the problem is PSPACE hard, we modify slightly the proof of Proposition 5. As before, we reduce the problem of *Emptiness of Finite Intersection of Regular Languages*, which is known to be PSPACE complete [13], to our problem.

Problem 2 (Finite Intersection of Regular Languages).

Input: $\mathcal{A}_1, \dots, \mathcal{A}_l$ a family of regular deterministic automata (on finite words) on the same finite alphabet Σ .

Question: Do we have $\mathcal{L}(\mathcal{A}_1) \cap \dots \cap \mathcal{L}(\mathcal{A}_l) = \emptyset$?

Let $\mathcal{A}_1, \dots, \mathcal{A}_l$ be a family of regular automata on the same finite alphabet Σ , with respective state space Q and transition functions $\delta_i: \delta_i(s, a)(t) = 1$ if there exist a transition from s to t with label $a \in \Sigma$ in \mathcal{A}_i . We build a probabilistic automaton $\mathcal{A} = (A, \Sigma', \delta, \alpha, F)$ such that \mathcal{A} is simple iff $\mathcal{L}(\mathcal{A}_1) \cap \dots \cap \mathcal{L}(\mathcal{A}_l) \neq \emptyset$.

Let x and y be two letters, not in Σ , and let $\Sigma' = \Sigma \cup \{x, y\}$.

- Q is the union of the state spaces of the \mathcal{A}_i , plus two extra states s and \perp . That is $Q = \bigcup_{i=1}^l Q'_i \cup \{s, \perp\}$, where the Q'_i are disjoint copies of the Q_i .
- The state \perp is a sink: for all $a \in \Sigma'$, $\delta(\perp, a)(\perp) = 1$.
- If u' is the copy of a non accepting state u of \mathcal{A}_i , we allow in \mathcal{A} the same transitions from u' as in \mathcal{A}_i for u : if $a \in \Sigma$, $\delta(u', a)(v') = 1$ iff v' is the copy of a state $v \in Q_i$ such that $\delta_i(u, a)(v) = 1$. Moreover we add a transition from u with label x : $\delta(u, x)(x) = 1$, and we add a transition from u with label y : $\delta(u, y)(\perp) = 1$.
- If u' is the copy of an accepting state u of \mathcal{A}_i , $i \in [1; l]$, the transitions from u' in \mathcal{A} are the same as in \mathcal{A}_i , plus an extra transition $\delta(u', x)(s) = 1$, and an extra transition $\delta(u', y)(\perp) = 1$.
- From state s in \mathcal{A} , with uniform probability on $i \in [1; l]$, when reading x , the system goes to one of the copies of an initial state of the \mathcal{A}_i 's, or to s .
- For the transitions which have not been precised, for instance if $a \in \Sigma$ is read in state s , the system goes with probability one to the sink \perp .
- The initial distribution α is the Dirac distribution on s .
- $F = \{s\}$

Given $\rho \in \mathcal{L}(\mathcal{A}_1) \cap \dots \cap \mathcal{L}(\mathcal{A}_l)$, the sequence $\{s\} \xrightarrow{x^{|Q|} x^\#} \rho \xrightarrow{y} \{s\}$ is an elementary cycle with a $\#$ -reduction. On the other hand, if $\mathcal{L}(\mathcal{A}_1) \cap \dots \cap \mathcal{L}(\mathcal{A}_l) = \emptyset$, it is straitforward to see that when reading an infinite word ρ on \mathcal{A} with initial distribution $\{s\}$, the induced process is simple: either ρ contains an infinite number of times the letter y , in which case with probability one after a finite number of steps a run loops on \perp , either ρ contains a finite number of y , and the process is deterministic, hence simple, after a finite number of steps. Thus, \mathcal{A} is simple if and only if $\mathcal{L}(\mathcal{A}_1) \cap \dots \cap \mathcal{L}(\mathcal{A}_l) \neq \emptyset$. See Example 4 for an illustration.

Example 4. Consider the following regular automata \mathcal{A}_1 and \mathcal{A}_2 , and the associated probabilistic automaton \mathcal{A} .

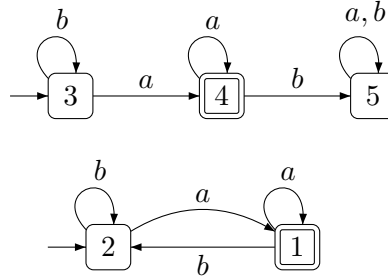

Figure 3. Automata \mathcal{A}_1 and \mathcal{A}_2

For instance, the word $b \cdot a \cdot a$ belongs to $\mathcal{L}(\mathcal{A}_1) \cap \mathcal{L}(\mathcal{A}_2)$. Then we can check that $\{s\} \xrightarrow{x^7} \{s, 3, 2\} \xrightarrow{x^\#} \{3, 2\} \xrightarrow{b \cdot a \cdot a} \{1, 4\} \xrightarrow{y} \{s\}$ is an elementary cycle with a $\#$ -reduction.

□

Details of Proposition 11. We prove Proposition 11.

Proof. Proposition 10 shows that **(2)** \Rightarrow **(1)**. We now show that **(1)** \Rightarrow **(2)**. Suppose that F is limit reachable from α in \mathcal{A} . First, if there exists $\rho \in \Sigma^*$ such that $\text{Supp}(\delta(\alpha, \rho)) \subseteq F$, then by definition F is reachable from $\text{Supp}(\alpha)$ in $\mathcal{G}_{\mathcal{A}}$.

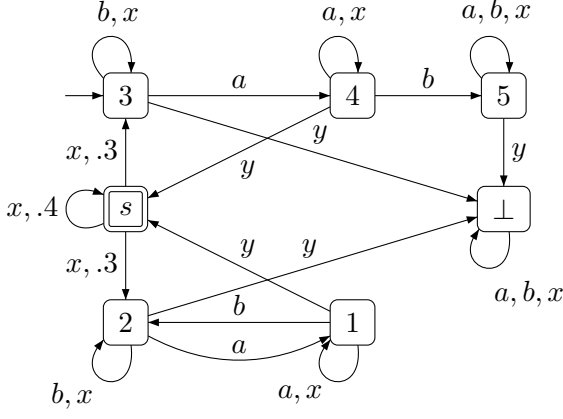

Figure 4. The probabilistic automaton \mathcal{A}

Suppose now that F is limit reachable from α in \mathcal{A} , but that for all $\rho \in \Sigma^*$ we have $\text{Supp}(\delta(\alpha, \rho)) \not\subseteq F$. We define the following probabilistic automaton \mathcal{B} with state space Q , alphabet Σ' and transition function as follows:

- $Q' = Q \cup \{\perp\}$ where \perp is a new state.
- $\Sigma' = \Sigma \cup \{e\}$ where e is a new symbol.
- We keep the same transitions on \mathcal{B} as in \mathcal{A} when the labels are in Σ .
- Given $q \in F$, we add an extra transition with label e which leads to a state $q \in Q$ with probability $\alpha(q)$.
- Given $q \in Q \setminus F$, we add an extra transition with label e which leads to state \perp with probability one.
- From state \perp , given any $a \in \Sigma'$ we loop with probability one on \perp .

We show that the automaton \mathcal{B} is not simple. Since F is limit reachable from α , we can let $\{\rho_n\}_{n \in \mathbb{N}}$ be a sequence of finite words such that for all $n \in \mathbb{N}$ we have $\delta(\alpha, \rho_n)(F) > 1 - \frac{1}{2^n}$. We define $w \in \Sigma'^\omega$ as:

$$w = \rho_1 \cdot e \cdot \rho_2 \cdot e \cdot \rho_3 \dots$$

We claim that the process induced on the state space Q of \mathcal{B} by w is not simple. First, notice that at any time, if the current distribution of the process is $\beta \in \Delta(Q)$ and the letter e is taken as input, then the probability to be in a state $q \in Q$ at the next step is equal to $\alpha(q) * \beta(F)$.

Given $k \in \mathbb{N}$, let $\beta_k \in \Delta(Q')$ be the distribution on Q' that we get after having read $\rho_1 \cdot e \cdot \rho_2 \cdot e \dots \rho_k \cdot e$. By the choice of the ρ_n , for all k we have $\beta_k(Q) > 1/2$. By hypothesis, there exists $q, q' \in Q$ such that $q \in \text{Supp}(\alpha)$ and such that for an infinite number of $n \in \mathbb{N}$ we have $q' \in \text{Supp}(\delta(q, \rho_n))$ and $q' \notin F$. Let $\gamma = \alpha(q)$. We have found a couple $q, q' \in Q$ such that:

- For all k we have $\beta_k(q) > \gamma/2$
- Infinitely often, $\delta(q, \rho_k)(q') > 0$ and $\delta(\alpha, \rho_1 \cdot e \dots \cdot e \cdot \rho_k)(q') < \frac{1}{2^k}$

Such a couple q, q' invalidates the Proposition 3 which holds for simple process. Indeed, by Proposition 3, if infinitely often we have $\mu_n^w(q) > \gamma$, then there exists $N \in \mathbb{N}$ and $\gamma' > 0$ such that for all $n_2 > n_1 \geq N$, if $\mu_{n_1}^w(q) > \gamma$ and $\delta(q, w_{n_1+1}^{n_2})(q') > 0$, then $\mu_{n_2}^w(q') > \gamma'$. Thus, \mathcal{B} is not simple. By Theorem 8, this implies that there exists an elementary cycle with a $\#$ -reduction in the extended support graph of \mathcal{B} . Since \mathcal{A} is supposed to be structurally simple, this imply that one of the words which appears among the labelings of the cycle contains the letter e . However, since for all $a \in \Sigma'$ we have $\delta(\perp, a)(\perp) = 1$, and since the cycle is elementary and contains a $\#$ -reduction, no set among the sets in the cycle can contain the state \perp . Notice that given $A \subseteq Q$, if $\perp \notin A \cdot e$ then $A \subseteq F$. This implies that a subset of F appears among the sets in the cycle. Since the letter e appears among the letters in the cycle, the set $\text{Supp}(\alpha)$ also appears among the sets in the cycle. This implies that there exists a paths between $\text{Supp}(\alpha)$ and F , i.e. that F is $\#$ -reachable from $\text{Supp}(\alpha)$ in the extended support graph of \mathcal{A} . \square

Details of Proposition 12. We prove Proposition 12.

Proof. First, we prove that given $S, T \subseteq Q$, we can decide in PSPACE whether (S, T) is an edge of $\mathcal{H}_{\mathcal{A}}$.

Using a method analogous to the proof of Proposition 5, we can decide in PSPACE whether there exists $\rho \in \Sigma^*$ such that $S \cdot \rho = T$. For the case of the $\#$ -edges, the proof follows from the following property:

If $S, T \subseteq Q$ and $\rho \in \Sigma^*$ are such that $S \cdot \rho = S$ and $S \cdot \rho^\# = T$, then there exists $\rho' \in \Sigma^*$ of length at most $|Q| \cdot 2^{|Q|}$ such that $S \cdot \rho' = T$.

Indeed, given $\rho \in \Sigma^*$ and $S \subseteq Q$, we define the link graph of ρ relative to S as the bipartite graph between couples (q, q') where $q \in S$ and $q' \in Q$ are such that $\delta(q, \rho)(q') > 0$. The property is a consequence of the fact that given $S \subseteq Q$ there are at most $|Q| \cdot 2^{|Q|}$ different link graphs of words relative to S .

Once again, we can use a method analogous to the proof of Proposition 5 to conclude the proof, by guessing the letters of ρ one by one and by updating the link graph.

Once we can decide in PSPACE whether (S, T) is an edge of $\mathcal{H}_{\mathcal{A}}$, it is simple to decide in PSPACE whether there exists a path in $\mathcal{H}_{\mathcal{A}}$ between to sets S and T . If there exists such a path, then there exists a path between S and T of length at most $2^{|Q|}$. We can guess in PSPACE the intermediate subsets which form the path, and solve the problem in PSPACE. \square

Details of Proposition 14. We prove Proposition 14.

Proof. We prove the following: a simple PA \mathcal{A} satisfies the qualitative limit parity problem iff there exists a set of states $A \subseteq Q$ such that:

- A is limit reachable from $\text{Supp}(\alpha)$
- There exists $\rho \in \Sigma^*$ of length at most $2^{|Q|}$ such that $A \cdot \rho \subseteq A$ and the parity condition is satisfied on the Markov chain induced by A, ρ .

This condition are PSPACE-complete, using the same kind of arguments as before. \square

Details of the product construction and Proposition 15.

Given $\mathcal{A}_1 = (S_1, \Sigma, \delta_1, \alpha_1)$ and $\mathcal{A}_2 = (S_2, \Sigma, \delta_2, \alpha_2)$ two simple automata on the same alphabet Σ , the construction of the product automaton $\mathcal{A}_1 \times \mathcal{A}_2 = (S, \Sigma, \delta, \alpha)$ is as follows:

- S is the cartesian product of S_1 and S_2 : $S = S_1 \times S_2$.
- Given $(s_1, s_2), (s'_1, s'_2) \in S$ and $a \in \Sigma$, $\delta((s_1, s_2), a)((s'_1, s'_2)) = \delta_1(s_1, a)(s'_1) \cdot \delta_2(s_2, a)(s'_2)$.
- Given $(s_1, s_2) \in S$, $\alpha((s_1, s_2)) = \alpha_1(s_1) \cdot \alpha_2(s_2)$.

Given $s = (s_1, s_2) \in S$, let $p_1(s) = s_1$ and $p_2(s) = s_2$ be the respective projections of s on the state spaces of \mathcal{A}_1 and \mathcal{A}_2 .

We now prove Proposition 15.

Proof. Let $A_1, A_2, \dots, A_l = A_1$ be a cycle in $\mathcal{H}_{\mathcal{A}}$. For all $i \in \{1, 2, \dots, l\}$, let $A_i^1 = p_1(A_i)$, and $A_i^2 = p_2(A_i)$. The sequences A_1^1, \dots, A_l^1 and A_1^2, \dots, A_l^2 are sequences of subsets of S_1 and S_2 respectively. If there exists an edge between A_i and A_{i+1} in $\mathcal{H}_{\mathcal{A}}$ which is not a $\#$ -edge, then clearly there exists an edge between A_i^1 and A_{i+1}^1 in $\mathcal{H}_{\mathcal{A}_1}$, and there exists an edge between A_i^2 and A_{i+1}^2 in $\mathcal{G}_{\mathcal{A}_2}$. All that we have to show is that, if there exists a $\#$ -reduction between A_i and A_{i+1} in $\mathcal{H}_{\mathcal{A}}$, then there exists a $\#$ -reduction between A_i^1 and A_{i+1}^1 in $\mathcal{H}_{\mathcal{A}_1}$ and there exists an edge between A_i^2 and A_{i+1}^2 in $\mathcal{H}_{\mathcal{A}_2}$, or there exists an edge between A_i^1 and A_{i+1}^1 in $\mathcal{H}_{\mathcal{A}_1}$ and there exists a $\#$ -reduction between A_i^2 and A_{i+1}^2 in $\mathcal{H}_{\mathcal{A}_2}$. This is also direct. As a consequence, if \mathcal{A} is not simple, then either \mathcal{A}_1 or \mathcal{A}_2 is not simple. This proves the result. \square

Details of Theorem 7. We prove Theorem 7.

Proof. First, remark that the stability of the class of languages recognized by parity automata under the positive semantics is trivial: we just consider a “union automaton” whose structure is the union of the structures of the two given automata, and whose initial distribution is a mix of the two given automata initial distributions.

We consider now the stability of this class of language under the intersection operator. Let \mathcal{A} be a simple parity automaton. Clearly, by defining a relevant set of accepting sets, we can transform it accepting condition to transform it to a positive Street PA which recognizes the same language. Since we do not change the structure of the automaton nor its transition function, the new automaton is still simple. Now, given two Street PA with the positive semantics, using a classical product construction, we can construct a Street PA which, under the positive semantics, accept a language which is the intersection of the languages of the two Street automata. By Proposition 15, this Street PA is still simple. Finally, using a construction a la Safra, we can construct a parity PA which, under the positive semantics, recognizes the same language as the last Street PA. We can show that the construction a la Safra keeps the automaton simple, since it can be seen as a product construction which does not add any probabilistic transition. We get the stability of the languages of positive parity PA under union and intersection.

Remark next that PA with positive parity semantics and PA with almost parity semantics are dual of each others: given a PA \mathcal{A} with positive parity semantics, by inverting the parity condition (taking a new parity function $p' = p - 1$), we get a new PA \mathcal{A}' whose language is the complementary of $\mathcal{L}^{>0}(\mathcal{A})$: $\mathcal{L}^{=1}(\mathcal{A}') = \mathcal{L}^{>0}(\mathcal{A})^c$. As a consequence, if the class of languages recognized by positive parity PA is stable under intersection and complementation, so is the class of languages recognized by almost parity PA. \square

D Details of Section 6

Details of Proposition 16. We prove Proposition 16.

Proof. By contradiction, suppose that \mathcal{A} is $\#$ -acyclic and not simple, i.e. there exists an elementary cycle $A_1 \rightarrow A_2 \rightarrow \dots \rightarrow A_k = A_1$ in the extended support graph $\mathcal{H}_{\mathcal{A}}$ of \mathcal{A} , such that at least one of the arrows corresponds to a $\#$ -reduction. By Proposition 10, if $A \rightarrow B$ is an edge in $\mathcal{H}_{\mathcal{A}}$, then B is limit reachable from A in \mathcal{A} . If \mathcal{A} is $\#$ -acyclic, then by Proposition 7 of [10] limit reachability implies reachability in $\mathcal{G}_{\mathcal{A}}$. This implies that there exists a path between A and B in $\mathcal{G}_{\mathcal{A}}$. Thus, since $A_1 \rightarrow A_2 \rightarrow \dots \rightarrow A_k = A_1$ is an elementary cycle in $\mathcal{H}_{\mathcal{A}}$, there exists a cycle in $\mathcal{G}_{\mathcal{A}}$. This is a contradiction.

The automaton of Example 2 is simple, since it does not contain an elementary cycle with a $\#$ -reduction. However it is not $\#$ -acyclic. This completes the proof. \square

Details of Proposition 17. We prove Proposition 17.

Proof. Let \mathcal{A} be a k -hierarchical automata. Let $C = B_1 \rightarrow B_2 \rightarrow \dots \rightarrow B_l = B_1$ be an elementary cycle in the extended support graph of \mathcal{A} . Let $i, j \in \{1, \dots, l\}$, let $q \in B_i$, and let $q' \in B_j$. By Lemma 8, there exists $\rho \in \Sigma^*$ such that $\delta(q, \rho)(q') > 0$, and there exists $\rho' \in \Sigma^*$ such that $\delta(q', \rho')(q) > 0$. This implies that $\text{rk}(q) = \text{rk}(q')$. This implies that there is not probabilistic transition in the cycle. As a consequence, C can not contain a $\#$ -reduction. This proves that \mathcal{A} is simple. The automaton of Example 2 is simple, but not hierarchical, which completes the proof. \square

E Details of Section 7

Details of Proposition 18. We prove Proposition 18.

Proof. We just have to show that for any $\alpha \in \Delta(Q)$ and $\rho \in \Sigma^*$, the process induced by ρ^ω and α on Q is simple. Let $\{X_n\}_{n \in \mathbb{N}}$ be the non-homogeneous Markov chain induced on Q by α and ρ^ω . Then for all $i \in \{0, 1, \dots, |\rho| - 1\}$, the chain $\{X_{n \cdot |\rho| + i}\}_{n \in \mathbb{N}}$ is homogeneous. The result follows from the classical decomposition

Theorem of the state space of an homogeneous Markov chain into periodic components of recursive classes, and transient states. □

Details of Theorem 8. We prove Theorem 8.

Proof. By the results of Section 4, if the *simple* almost or positive parity problem is satisfied, then it is satisfied by a lasso shape word. Along with Proposition 18, this implies that the simple almost or positive parity problem is equivalent to the question whether there is lasso shape word that is accepted with probability 1 (or positive probability). Since the simple almost or positive parity problem is PSPACE-complete, we get the theorem. □